

Nice

Apollo
Gate Operators

7300ETL-1K
Residential & Light Duty
Commercial Slide
Gate Operator

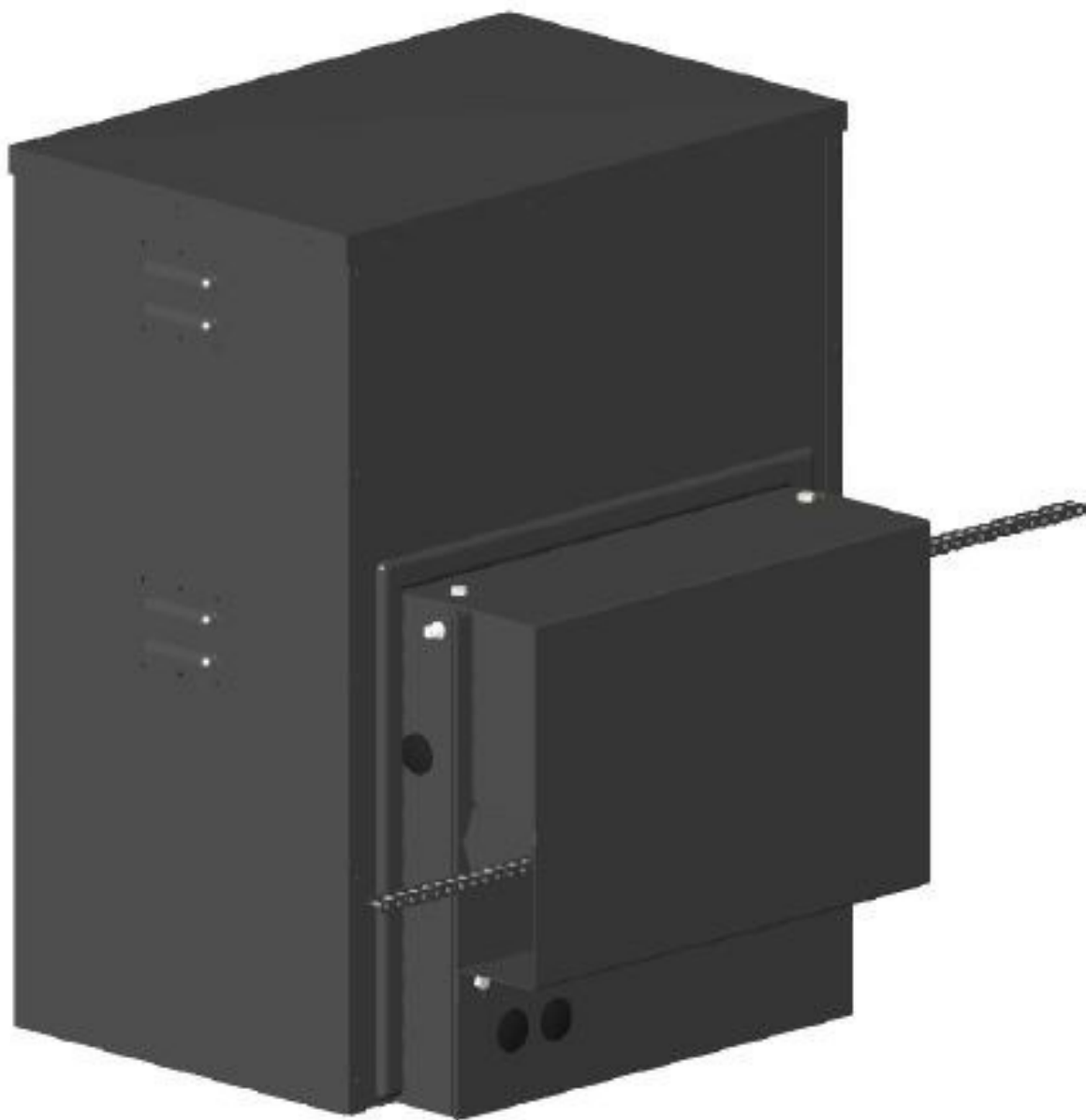

INSTALLATION MANUAL

Table of contents

IMPORTANT SAFETY INSTRUCTIONS	II
APPLICATION	III
PRE-INSTALLATION CHECKLIST	IV
PART IDENTIFICATION	6
<i>Optional parts identification</i>	
1. PAD INSTALLATION	7
1.1 - 7300ETL-1K PAD INSTALLATION PROCEDURES	
2. OPERATOR INSTALLATION	8
2.1 - <i>Mounting the Operator on the PAD</i>	
2.2 - <i>Chain Bracket Installation</i>	
2.3 - <i>Chain and Bolt Installation</i>	
2.4 - <i>Left and Right hand Wiring</i>	
2.5 - <i>Learning and Limit Switch Adjustment</i>	
3. CIRCUIT BOARD LAYOUT	15
4. OUTPUTS & INPUTS	16
4.1 - <i>Gate Operator Accessory Inputs</i>	
4.2 - <i>Communication buses</i>	
4.2.1 - <i>BLUEBUS ACCESSORIES</i>	
4.2.2 - <i>Programming the plug-in receiver and remote controls</i>	
4.3.3 - <i>OVIEW REMOTE CONTROL</i>	
5. WIRING AND CONNECTIONS	19
6. OPTIONAL INPUTS/OUTPUTS	20
6.1 - <i>Fire dept. connection</i>	
6.2 - <i>Exit and edge inputs wiring diagram</i>	
6.3 - <i>Guard station</i>	
6.4 - <i>Magnetic lock connection</i>	
6.5 - <i>Radio receiver connection (third party)</i>	
7. INSPECTION AND OPERATION	21
8. GENERAL LAYOUT AND SAFETY ACCESS	22
9. ACCESSORIES AND SENSORS	23
10. BOARD DIAGRAM	24
11. PROGRAMMING BUTTONS	25
11.1 - <i>Force</i>	
11.2 - <i>Speed</i>	
11.3 - <i>Acceleration</i>	
11.4 - <i>Delay</i>	
11.5 - <i>Function</i>	
11.6 - <i>Display</i>	
12. GLOSSARY	30
13. EMERGENCY VEHICLE ACCESS	31
14. MAINTENANCE SCHEDULE - APOLLO GATE OPENER	32
15. APOLLO GATE OPENER TROUBLESHOOTING	32
16. APOLLO 7300ETL-1K PROGRAMMING QUICK START	33
17. PUTTING THE CONTROLLER INTO LEARNING MODE	33
18. INSTALLATION CHECKLIST	34
WARRANTY INFORMATION	

IMPORTANT SAFETY INSTRUCTIONS

WARNING - To reduce the risk of injury or death:

- **READ AND FOLLOW ALL INSTRUCTIONS.**
- **Installation should be performed by a professional installer.**
- **Required welding should be performed by a qualified welder.**
- **Should electricity be required, use a certified electrician only.**
- **Any device that requires 120 Volts AC should be U.L. approved.**
- **Review with the owner all safety concerns including:**
 - ⇒ **Do not operate the gate unless area around gate is in full view.**
 - ⇒ **Never let children operate or play with gate controls. Keep the remote control away from children.**
 - ⇒ **Always keep people and objects away from the gate. NO ONE SHOULD CROSS THE PATH OF THE MOVING GATE.**
 - ⇒ **Periodically test the obstruction sensitivity to assure safe and proper operation. *Do not test sensitivity by standing between the gate and the hinge or stop post.***
 - ⇒ **The “CAUTION AUTOMATIC GATE” signs should be clearly visible from both sides of the gate.**
 - ⇒ **Always insure that the gate has closed securely before leaving area.**
 - ⇒ **Arrange with local fire and law enforcement for emergency access.**
- **Use the emergency release only when the gate is not moving.**
- **A secondary entrapment device such as loop detectors, edge switches, and beam detectors are highly recommended and required to meet the UL325 standard.**
- **Install control devices such as keypads far enough away (5 feet or further) from any moving parts of the operator and gate to prevent possible injury.**
- **Do not install control box where the gate can come in contact with person using the push button on side of control box.**
- **Always disconnect the battery or power source when making adjustments or repairs to any part of the gate or operator.**
- **All rollers should be covered to prevent injury.**
- **KEEP GATES PROPERLY MAINTAINED.** Read the owner’s manual. Have a qualified service person make repairs to gate hardware.
- **The entrance is for vehicles only. Pedestrians must use separate entrance.**

Test the gate operator monthly. The gated entrance MUST reverse on contact with a rigid object or stop when an object activates the non contact sensors. After adjusting the force or limit of travel, retest the gate operator. Failure to adjust and retest the gate operator properly can increase the risk of injury or death.

SAVE THESE INSTRUCTIONS

APPLICATIONS

The **Apollo Model 7300ETL-1K Slide Gate Operator** is designed to handle a slide gate up to 25 feet in total length and 800 lbs. A professional fence or gate dealer is recommended to assure proper installation. **Apollo Gate Operators** are available only through qualified dealers with an outstanding reputation in the fence and gate industry. These dealers will be able to recommend the proper equipment for particular applications. **Apollo Gate Operators** are 12 Volt DC (*Direct Current*) powered. A 12 Volt sealed battery (33 ampere hour minimum) is recommended. There are several advantages with 12 Volt DC systems:

- **Low voltage virtually eliminates risk of electrical shock.**
- **Battery powered operators provide up to 200 operations in the event of power outages.**
- **The battery may be recharged with a trickle charger or by solar energy (Electrical battery chargers should have a class 2 transformer rating).**

With Battery connected to trickle charger (use Part# 404C from page 6)

If a trickle charger is used and a standard electrical outlet is not readily available, a licensed electrician will be required for proper electrical hook up.

The Charging Method table below should be used as a guide for capacity of operation of operators only, additional options may reduce the the daily usage. *Please note that the charge capability of solar panels will vary with different geographical locations, please refer to Table 1 below.*

1050 Gate Operator Solar Charge Controller (With Solar Panel)

The built-in solar charge controller provides maintenance-free protection for 12VDC batteries and solar panels by preventing overcharging. Charging current is adjustable from 0.10 Amps to 1.50 Amps in 0.05 Amp increments, with adjustable cycle times and Auto Off/On. The battery charge profile may be manually adjusted to match a particular battery's specifications, or default settings can be used to maintain the majority of 12VDC batteries on the market. The charging algorithm is temperature compensated using a built-in temp sensor to further protect batteries against overheating and overcharging.

Specifications	
Charging Current:	.10 – 1.50A in .05A increments
Cycling On/Off:	4s – 30s in 1s increments
Auto:	Off/On

Charging Methods for Average Daily Usage

Daily Cycles	1-10	1-20	1-40	1-60	1-80	80+
5 watt solar panel →	*					
10 watt solar panel		*				
20 watt solar panel			*			
40 watt solar panel					*	
1.5 amp battery charger					*	
10 amp battery charger						*

Table 1

Note: Double the amount of solar panels for Dual Gate Operators.

PRE-INSTALLATION CHECKLIST

The following check list should be used before beginning installation:

Verify that the proper operator has been selected for this application.

Verify proper installation and operation of the gate.

- 1. Are all rollers covered with protective housing?*
- 2. Are all rollers serviceable*
- 3. Does the gate roll free and level?*
- 4. Are the main posts sturdy enough to handle the gate & operator?*
- 5. Does the gate meet U.L. construction?*

Determine the general location of the operator, attachment points, and solar panel (if used).

- 1. Is there a suitable location for the operator?*
- 2. Can the solar panel (if used) be mounted in an unobstructed area facing south (in the northern hemisphere)?*
- 3. Will additional solar panel cable be required?*
- 4. Is electricity available (if required)?*

Consider safety and access options. Recommend if needed.

- 1. Will there be children or animals in the area?*
- 2. Are safety loops, edge switches, or photo beam detectors required?*
- 3. How can the gate be opened in emergencies?*
- 4. How will visitors enter and exit?*
- 5. Will vehicles (and trailers) have sufficient room off roadway to operate any control devices such as keypads?*

IMPORTANT

Never weld parts to the gate or posts when the operator circuit board is powered. Doing so may damage the board beyond repair and void your warranty.

PART IDENTIFICATION

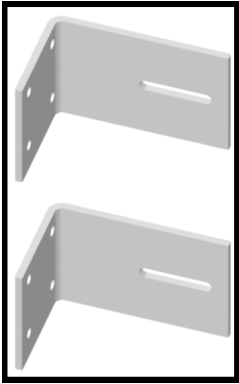

**Part# 10020715
Chain Brackets (2)**

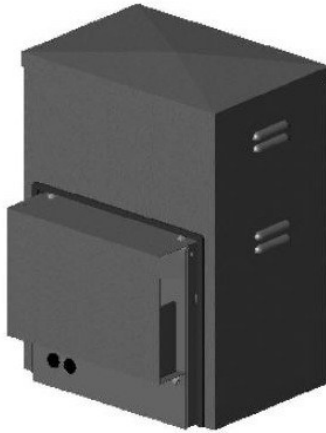

Operator

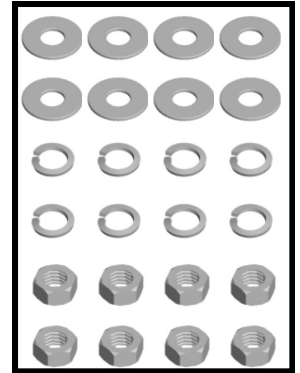

**5/16 Washers, Lock Nuts, & Nuts
(8 each)**

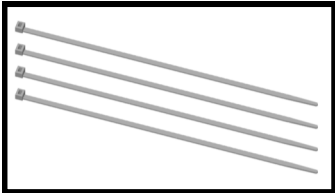

Tie Wraps (4 each)

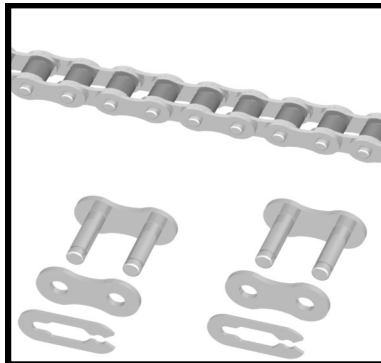

**Part # 7252001
Master Chain Links (2 each)
and
#40 Roller Chain (35 feet)**

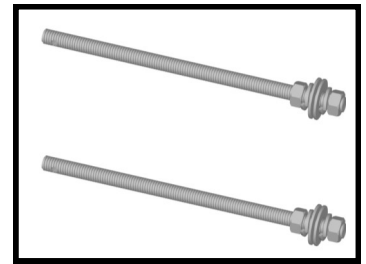

**Part # 10003115
Chain Bolts with hardware (2 each)**



**Part# 273 - CAUTION Sign
(2 each)**

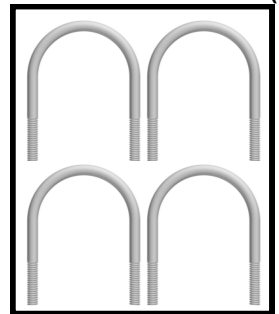

5/16 U Bolts (4 each)

OPTIONS

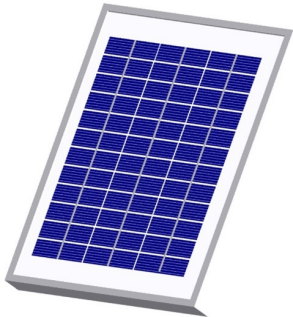

**Part# 201
5 Watt Solar Panel &
Bracket**



Part# OVIEW



**Part# 320N
Nice Transmitter**



**Part# A2058 Cable Harness for (8')
Part# A2014 Cable Harness for (38')**



Part# FT210B



**Part# 404C
Automatic Battery Charger**



Part#: MOFB



Part# MOTB

PAD INSTALLATION

1 - 7300ETL-1K PAD INSTALLATION PROCEDURES

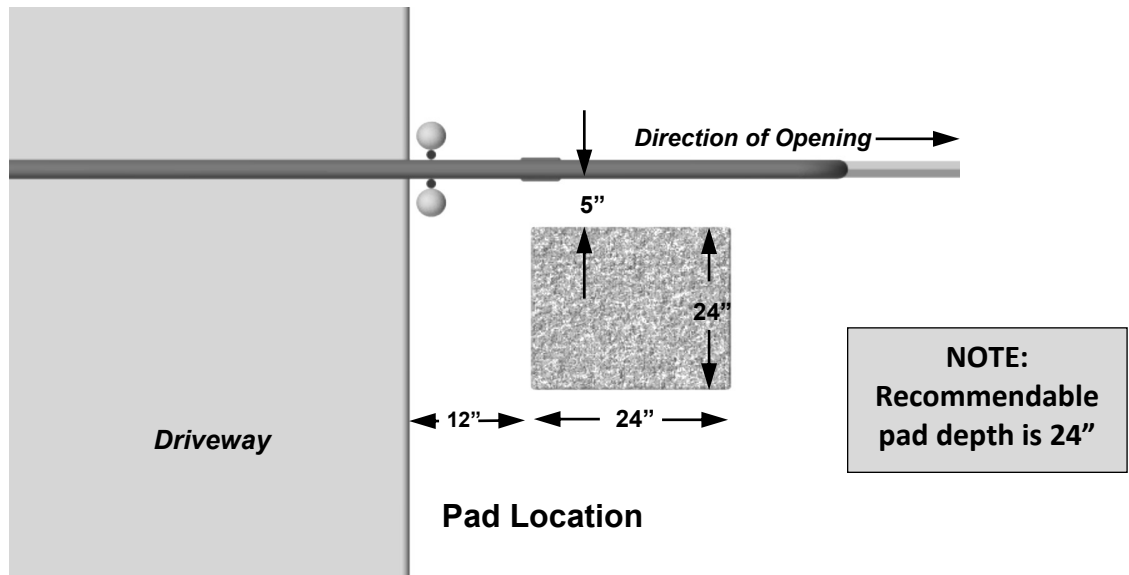

Figure 1: Pad Location

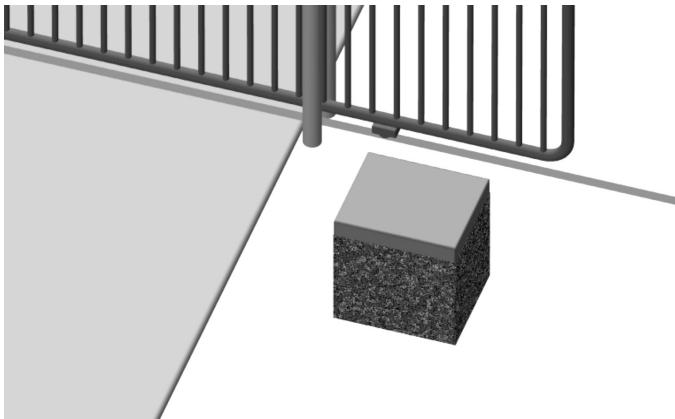

Figure 2: Overview of Pad Location

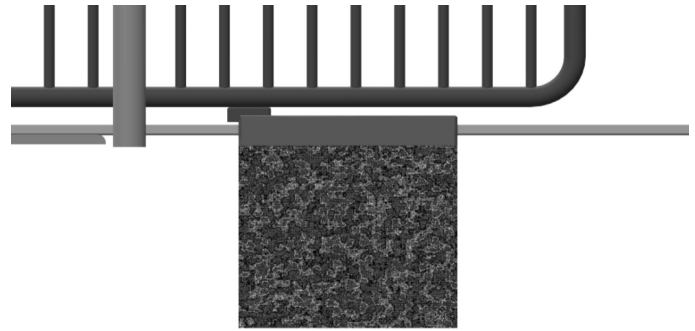

Figure 3: Pad Distances location

Conduit requirements should be considered in the planning stage. If electrical power is required, a separate conduit should be installed for electrical only. A certified electrician should be consulted for the proper conduit material (Figure 4 & 5).

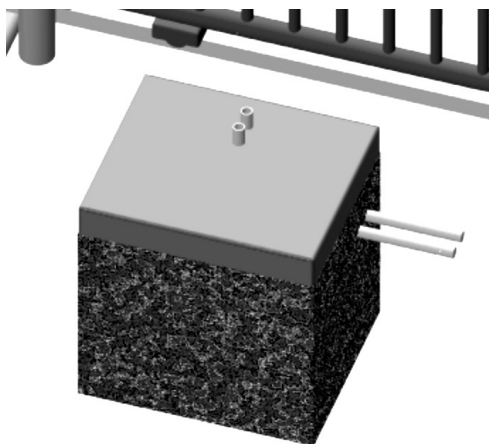

Figure 4: Pad Location with Conduit

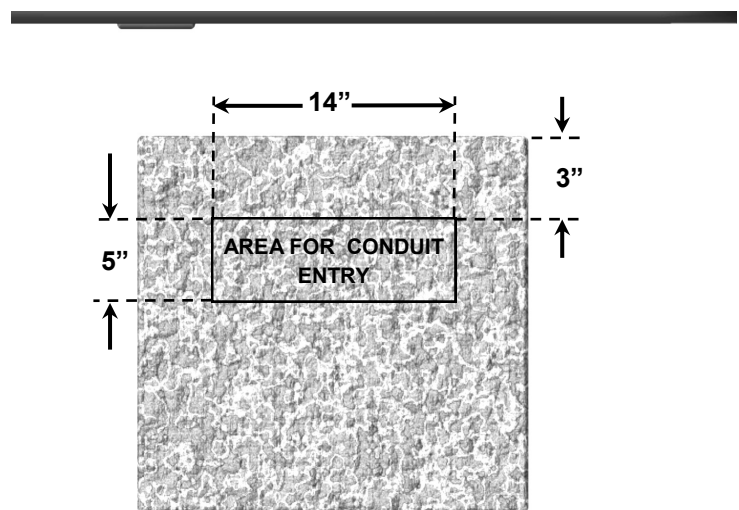

Figure 5: Pad Location with Conduit Area

OPERATOR INSTALLATION

2 - 7300ETL-1K OPERATOR INSTALLATION

2.1 - Mounting the Operator on the Pad

Four 1/2" dia. X 3" length, anchor bolts (not supplied) are recommended to mount the chassis. The holes should be drilled with a 1/2" concrete drill bit.



Figure 6: Anchor Bolts

STEP 1. Set the operator on the pad as shown. Align the sprockets 3 to 5 inches from the inside surface of the gate.

STEP 2. Mark the four mounting holes on the pad.

STEP 3. Remove the operator and drill the holes according to the anchor bolt manufacturers instructions.

STEP 4. Replace the operator and fasten to the pad.

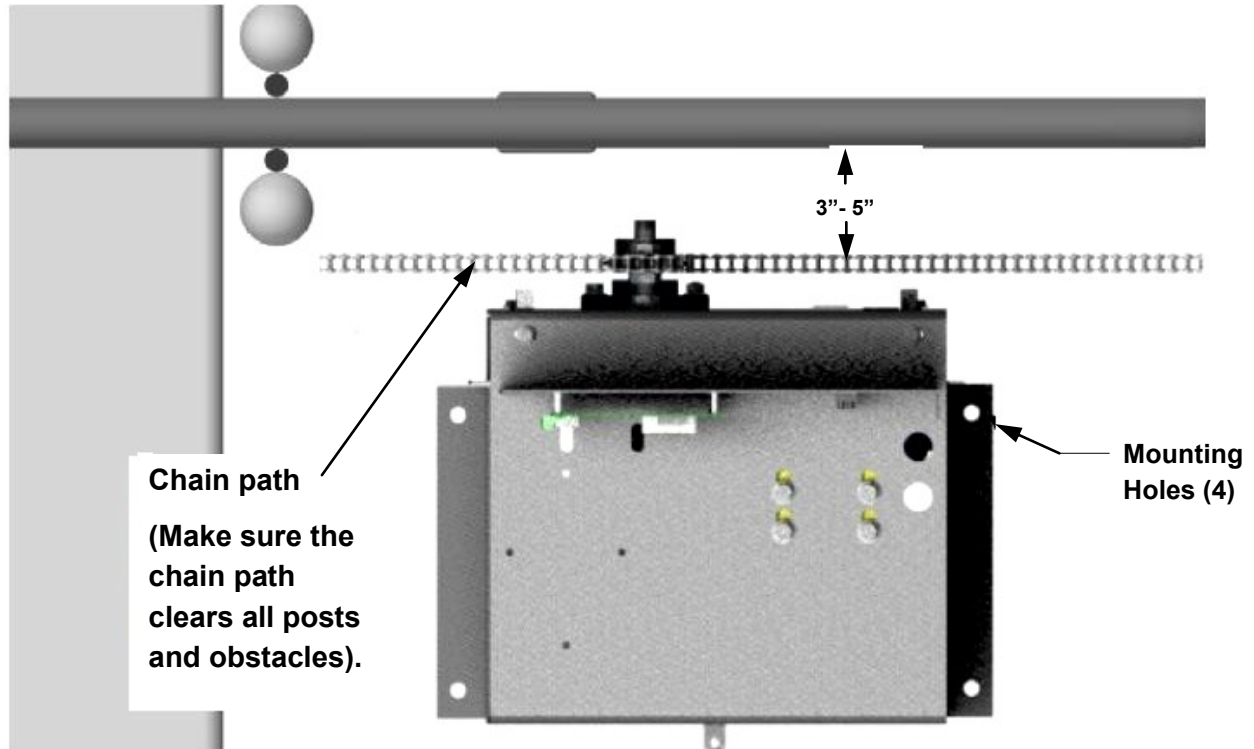

Figure 7: Operator and chain alignment

TOP VIEW

2 - 7300ETL-1K OPERATOR INSTALLATION (Continued)

2.2 - Chain Bracket Installation:

STEP 1. Assemble chain bracket with 5/16" U-bolt & hardware to each end of the gate as shown.

Do not tighten at this time.

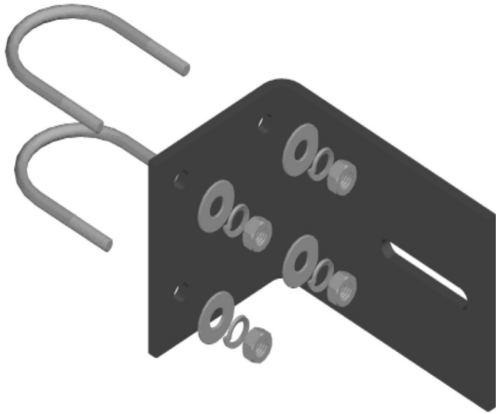

Figure 8: Gate and Bolt Assembly

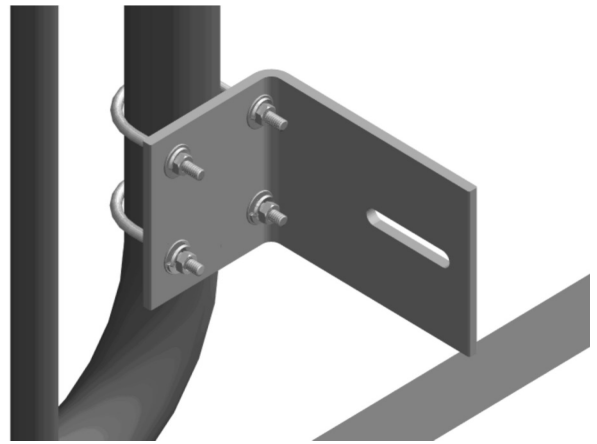

Figure 9: Gate and Bolt Assembly

STEP 2. Align the left chain bracket slot with the top teeth of the idler sprocket.

Note: If welding equipment is available, tack weld the chain bracket to the gate on each end to prevent slippage

Idler Sprocket

Main Sprocket

STEP 3. Align the right chain bracket slot with the bottom teeth of the main sprocket.

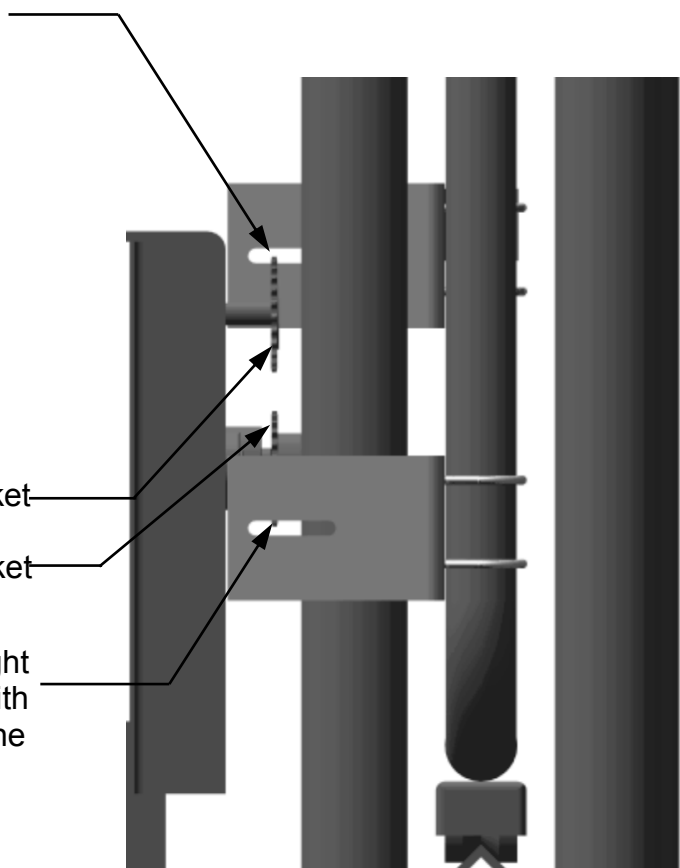

Figure 10: Chain Assembly

STEP 4. Tighten all hardware.

2 - 7300ETL-1K OPERATOR INSTALLATION (Continued)

2.3 - Chain & Bolt Installation

STEP 1. Position the gate so that the operator is in the center of the gate. Connect chain bolt to the chain bracket as shown on both ends of the gate.

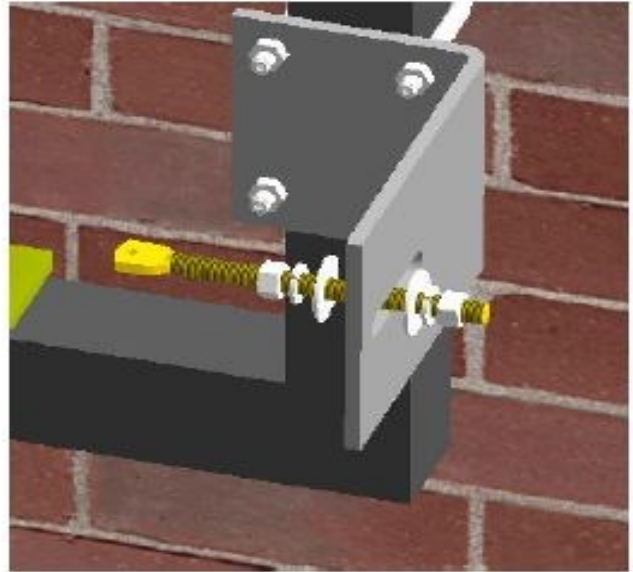

Figure 11: Chain and Bracket Installation

STEP 2. Attach the chain to the chain bolt using the master chain link. Do not tighten the chain bolts .

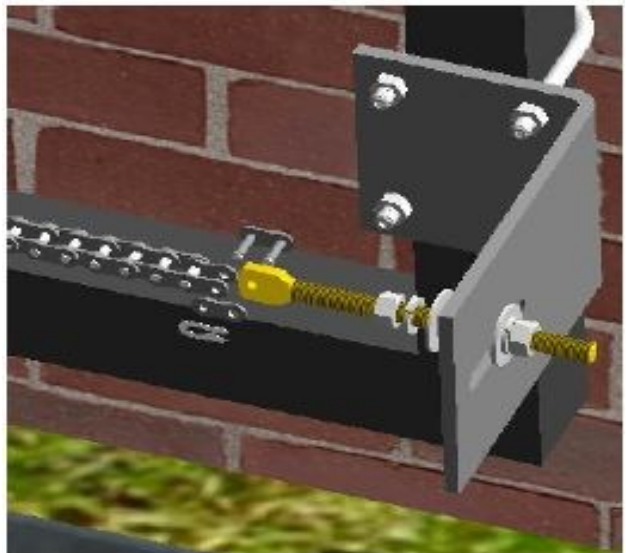

Figure 12: Chain and Bracket Installation



Note: A chain breaking tool may be required to reduce the chain to proper length.

Figure 13: Chain Rotation position

2 - 7300ETL-1K OPERATOR INSTALLATION (Continued)

2.4 - Left Hand and Right Hand Operation Wiring

Left-Closing Gate Limit-Switch and Motor Wiring

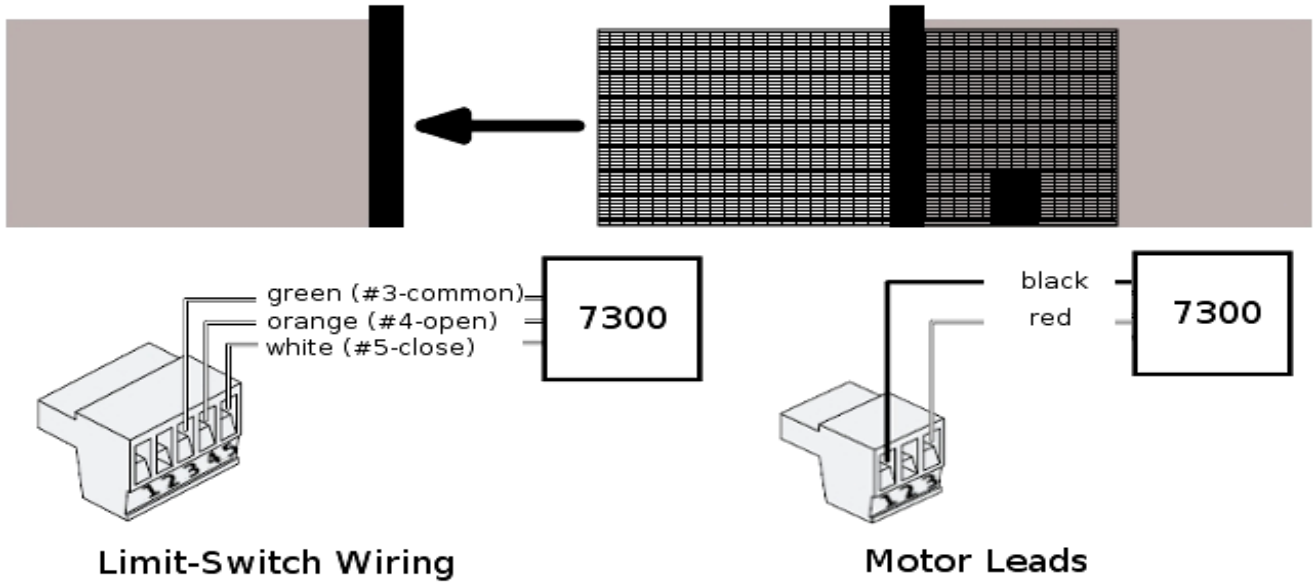

Figure 14: limit switch wiring for left hand operation

Right-Closing Gate Limit-Switch and Motor Wiring

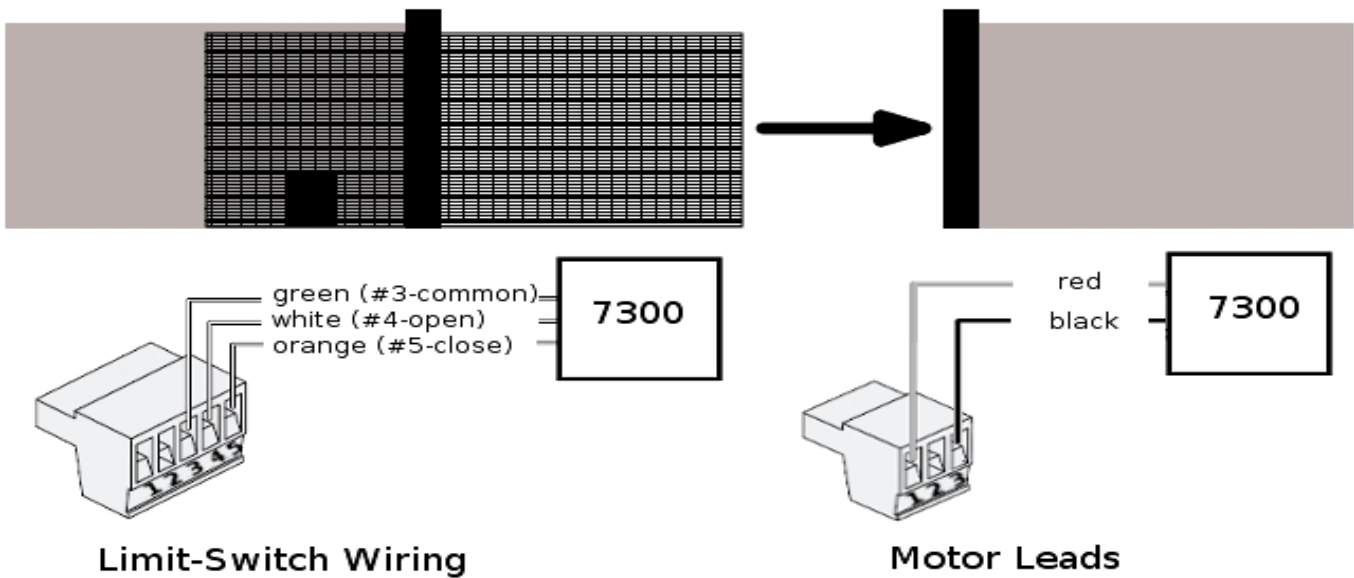

Figure 15: limit switch wiring for right hand operation

Connect the 7300 motor power and control wiring as shown here for motor 1. For a Dual Slide Gate installation, for Motor 2 connection, reverse motor power leads (black and red) and swap position of orange and white limit switch wiring:

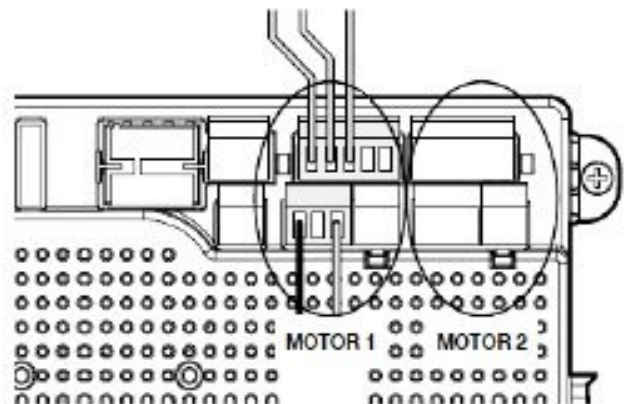

Figure 16: 7300ETL-1K CONNECTION AT THE 1050 Control Board

2 - 7300ETL-1K OPERATOR INSTALLATION (Continued)

2.5 - Learning and Limit switch adjustment

Apollo has taken great care to simplify the installation, operation and safety of this device and to ensure longevity and reliability of the unit over time. The learning procedure consists of the following steps shown below:

1. Install all gate accessories such as Photo-Eye's, Sensors, Loops and other safety devices.
2. Using the MANUAL RELEASE, disengage the drive motor if this is not already accomplished as shown in Figure 18 (Below).
3. Move the gate manually (with your hands) to ensure that the gate travels to the fully open and fully closed positions with no binding or problems. Gate should move freely. The control board is already in the "LEARNING MODE" when shipped. If not in learning mode press FUNCTION then press LEARN then press SLIDE then press LIGHT, AVERAGE OR HEAVY, then press ENTER.
4. Manually move the gate mid-way and engage mechanical release (see Figure 17 Quick Realse Engage). Test motor direction by pressing OPEN. If the gate instead CLOSES swap the RED and BLACK motor leads shown in Figure 14 & 15, 7300 MOTOR WIRING DIAGRAM. Using the OPEN button on the front of the Control board, hold the button down until the gate reaches the fully intended open position.

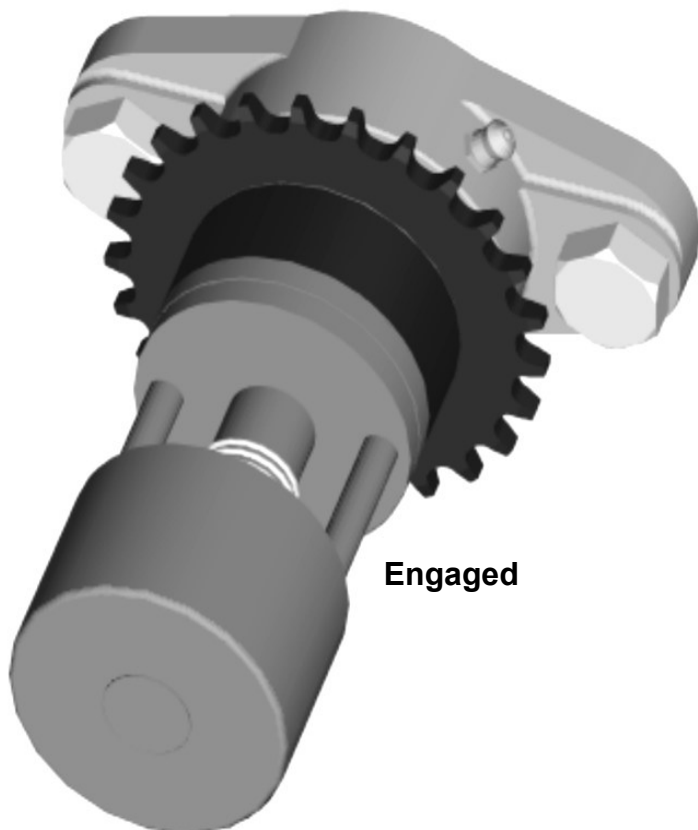

Figure 17: Quick Release Engaged

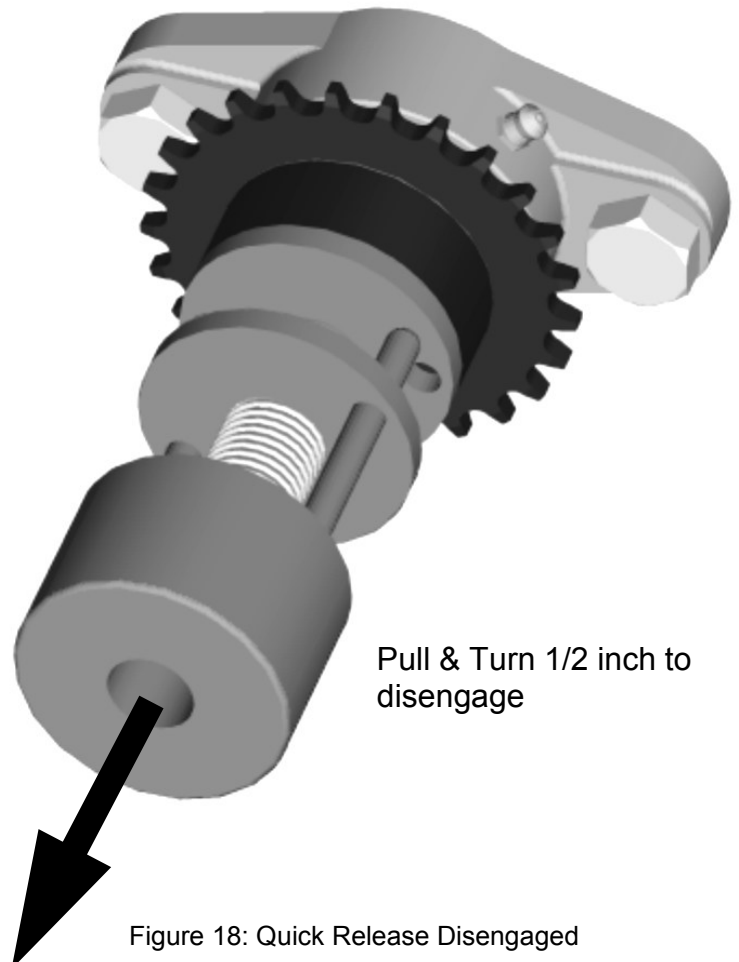

Figure 18: Quick Release Disengaged

2.5 - Learning and Limit switch adjustment (Continued)

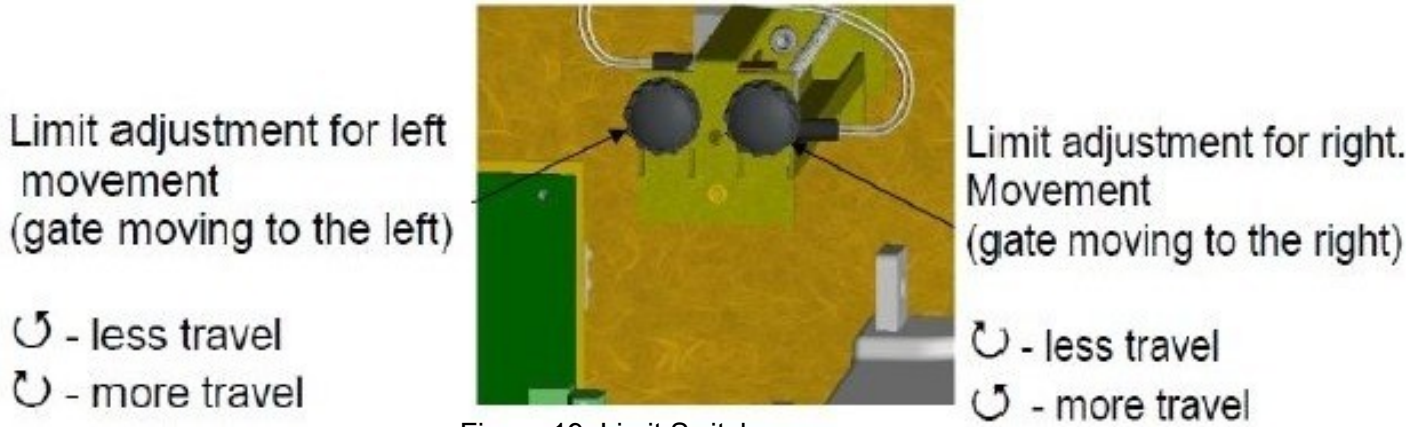

Figure 19: Limit Switch

5. Adjust the Open Limit Switch (See Figure 19) until the GREEN light illuminates on the front of the control board (See Figure 20). The FULLY OPEN limit switch is now set.

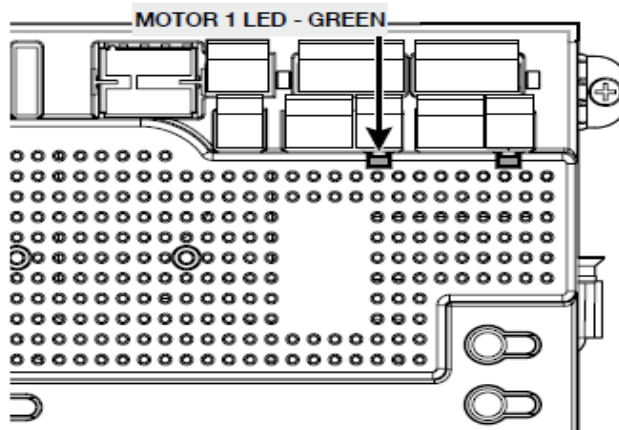

Figure 20: Green Open LED

6. Using the CLOSE button on the front of the Control Board, hold the button down until the gate reaches the fully intended closed position.
7. Adjust the Closed Limit Switch (See Figure 19) until the RED light illuminates on the front of the control board (See Figure 21). The fully CLOSED limit switch is now set.

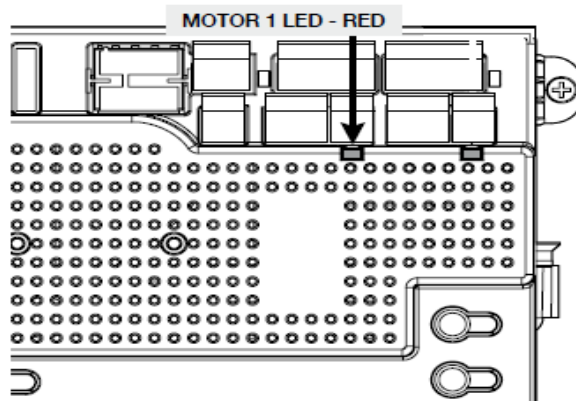

Figure 21: Red Closed LED

2 - 7300ETL-1K OPERATOR INSTALLATION (Continued)

2.5 - Learning and Limit switch adjustment (Continued)

8. Press "OK" to allow the control board to scan for attached items, such as sensors, photo-eye's and other safety devices.
9. The gate will open partially then stop. This is being done, so the control board can sense the type and operational condition of the drive motor. The gate will then run to the closed limit switch so the board can properly sense the intended closed position.
10. The control board will then OPEN the gate slowly to establish travel and intended open position by sensing the open limit switch.
11. Once the gate reaches the OPEN limit switch, the control board will now increase gate travel speed to the highest speed allotted, and will now travel to the CLOSED limit switch position at full speed.
12. The gate opener is now programmed for basic usage.

3 - CIRCUIT BOARD LAYOUT

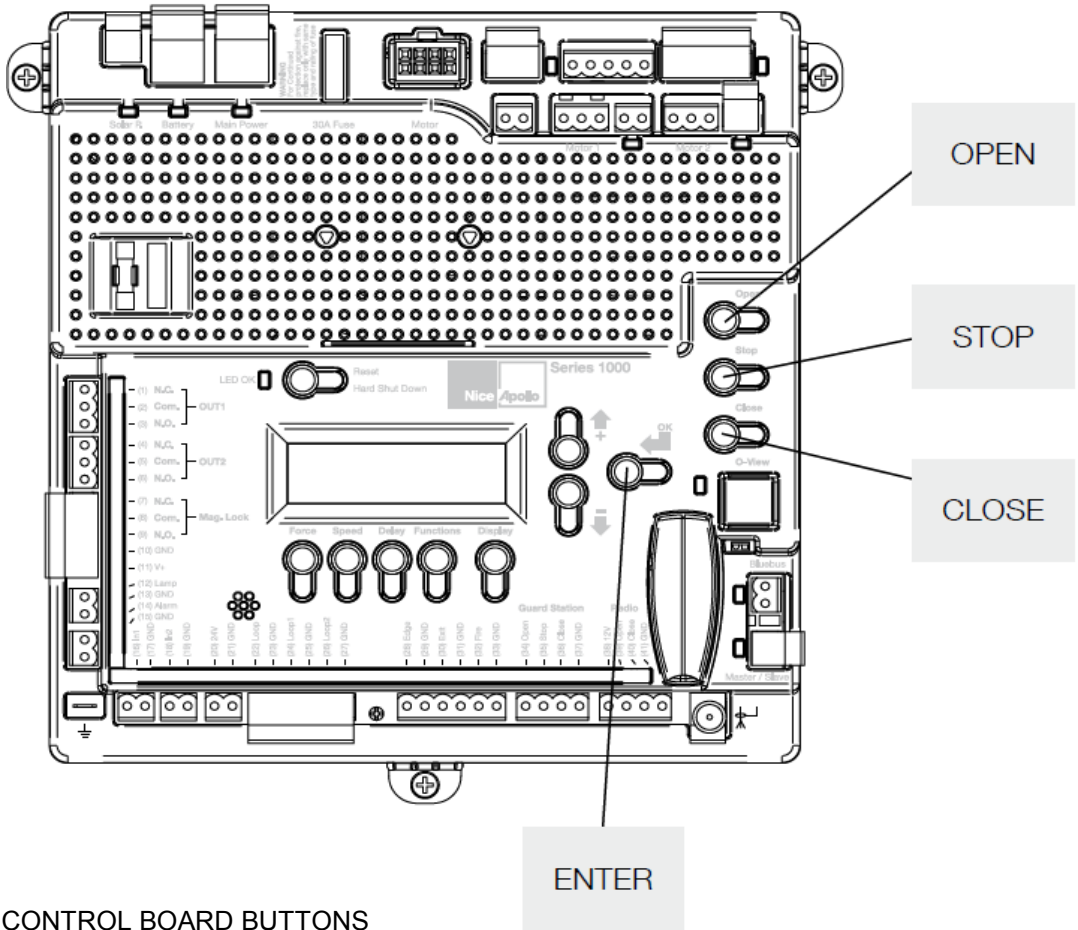

Figure 22 - CONTROL BOARD BUTTONS

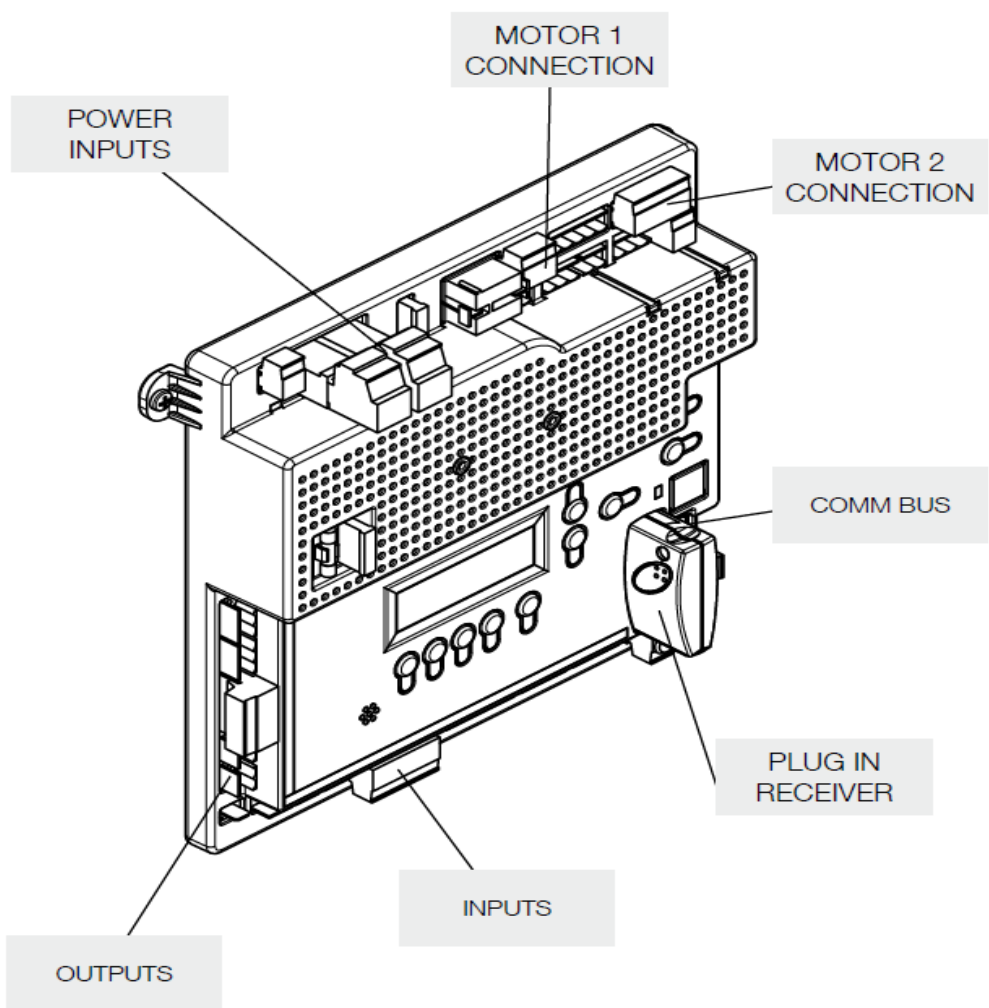

Figure 23 - CIRCUIT BOARD LAYOUT

4 - OUTPUTS & INPUTS

Commercial Gate Operator Accessory Outputs:

OUT1 and OUT2: Individual, isolated relays provide COMMON, NORMALLY OPEN, and NORMALLY CLOSED dry contacts for switching accessories based on programming of the "Auxiliary IO" function. These outputs are programmed in the "FUNCTION Auxiliary I/O" menu.

Magnetic Lock: Provides fused power (1.85A max) and isolated relay COMMON, NORMALLY OPEN, and NORMALLY CLOSED dry contacts for electrically powered and maintained magnetic locks. The delay for magnetic lock activation/deactivation may be adjusted from 0 to 5 seconds.

Lamp: Provides fused power (1.85A max) to drive a flashing warning lamp to indicate gate operation. This output is active when the gate is operating (Opening and Closing). Sets the amount of time the lamp accessory output is activated prior to gate movement. Settings from 0 to 5 seconds with a step of 0.5 seconds.

Alarm: Provides fused power (0.5A @ 12VDC) to drive an alarm siren to signal the occurrence of a hard shutdown, caused by 2 consecutive entrapment events (signals). This alarm output is reset by pressing the "Reset Hard Shutdown" button on the front panel or activating the "FIRE" input.

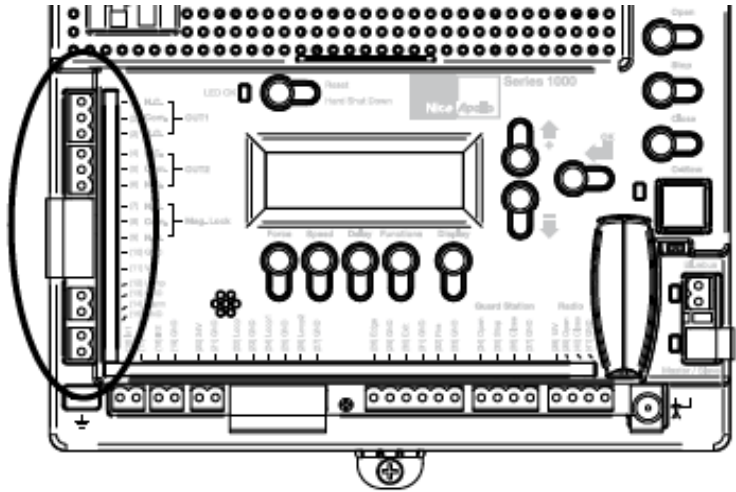

Figure 24 - BOARD OUTPUTS

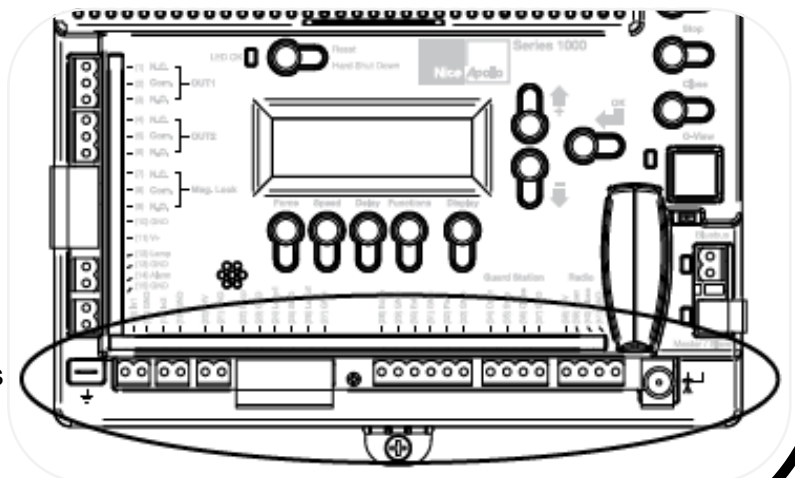

Figure 25 - INPUTS

4.1 - Gate Operator Accessory Inputs

Auxiliary Inputs 1 (16) and 2 (18): These digital inputs may be connected to the digital outputs of accessories and programmed to activate or control the gate operator in a number of different modes. Shorting pin 1 to pin 2 through a dry contact activates the programmed settings for these input. These inputs are programmed in the "FUNCTION Auxiliary I/O" menu.

LOOP Input: (22) Dry contact input that can be programmed for an inductive safety loop or photo-eye detector. Shorting the digital input to GND reverses a closing gate to the full open position. The opened gate is held opened for as long as the LOOP input is active. (SAFETY)

LOOP 1 Input: (24) Dry contact input that can be programmed for an inductive safety loop or photo-eye detector. Activating the LOOP 1 input maintains an OPEN gate fully open and a CLOSED gate fully closed until deactivated. (SHADOW) Setting the LOOP1 input to "Photo Mode" causes the moving gate to stop, then reopens the gate when the LOOP1 input is deactivated.

LOOP 2 Input: (26) Dry contact input that can be programmed for an inductive safety loop or photo-eye detector. Activating the LOOP2 input (26) while the gate is opening cause the gate to close to the fully closed position. This loop input is intended for use with safety sensors to prevent entrapment between the opening gate and an adjacent wall or structure.

Edge Input: (28) This input may be configured as "DIGITAL" or "ANALOG" as required by the sensor type. When configured as "DIGITAL", this is a dry contact input; otherwise when configured as "ANALOG", the input must measure 8200ohms. When the input is activated it stops the gate regardless of direction of travel, momentarily reverses it then stops.

Exit Input: (30) Dry contact input for a vehicle exit sensor. Opens gate from the closed position and holds gate open with maintained input or reverses gate if closing.

Fire Input: (32) Dry contact input for a fire department control switch. Opens the gate and holds the gate open until the control switch is deactivated. This input is "hold to run". Auto-close is disabled when this input is activated. Also clears hard shutdown.

4.1 - Gate Operator Accessory Inputs (Continued)

Guard Station Open: (34) Dry contact input for a guard station open switch. Momentarily shorting the digital input to GND opens the gate to the full open position with the subsequent auto-close feature enabled.

Guard Station Stop: (35) Dry contact input (Normally Closed) for a guard station stop switch. Momentarily opening this input stops the opening gate at its current position. While this input is activated, all other inputs are disabled and are not functional.

Guard Station Close: (36) Dry contact input for a guard station close switch. Momentarily shorting the digital input to GND closes the gate (master and slave).

RADIO

Radio Open: (39) Dry contact input for an accessory radio open switch. Momentarily shorting the digital input to GND opens the gate to the full open position with the subsequent auto-close feature enabled.

Radio Close: (40) Dry contact input for an accessory radio close switch. Momentarily shorting the digital input to GND closes the gate.

Radio Input: Open/Close: (39 and 40) If you tie open and close together the unit will operate like a garage door opener in the instance that each time you press the button, it will either OPEN, STOP or CLOSE.

4.2 - Communication buses

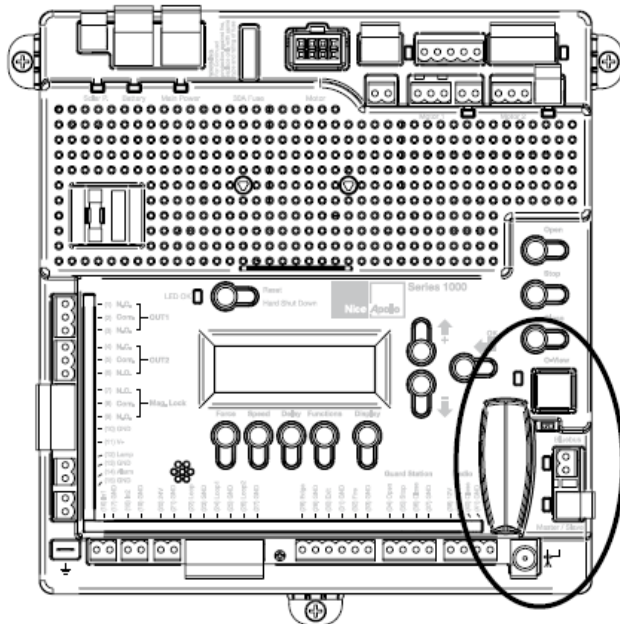

Figure 26 - COMMUNICATION BUSES

4.2.1 - BLUEBUS ACCESSORIES

MOTB: Moon Touch programmable keypad with secure codes (up to 9 digits per code if required) to control gate opening and closing. Connects to the 2-wire BlueBUS connector with inexpensive unshielded twisted-pair wire.

FT210B/MOFB: Photocell transmitter and receiver pair that connects to the 2-wire BlueBUS connector with inexpensive unshielded twisted-pair wire and is a monitored, non-contact sensor for entrapment protection as specified in UL325, Section 31.1 "General Entrapment Protection Provisions".

Master Slave:

This interface is not used in this application

4.2.2 - Programming the plug-in receiver and remote controls

SMXI/A Plug-In Receiver:

The SMXI/A 433Plug-In Receiver provides up to 15 channels for specific control of individual gate functions. The receiver includes built-in programming functions for adding or removing Nice FloR/A wireless remote controls to/from a gate installation. The following procedures detail the steps to assign a remote control, add a new remote control, delete a single remote control, or remove all remote controls from the receiver memory.

Programming the FloR/A 2-Button or 4-Button Remote Control with the SMXI/A Plug-In Receiver.

These procedures apply to the FloR/A wireless remote control. These procedures assign factory default controls automatically to the remote control.

1. Have a functioning Nice FloR/A 2-button or 4-button remote control with a battery installed prior to programming the remote control.
2. Press and hold the button on the side of the SMXI/A receiver until the led illuminates green on the SMXI/A receiver, then release the button.
3. Within 10 seconds, press and hold any key on the FloR/A remote control until the led in the SMXI/A receiver blinks green 3 times, indicating that the FloR/A is programmed to control the receiver.
4. After the led on the SMXI/A receiver blinks green 3 times, another 10 second interval is started to program another FloR/A remote control if desired. Repeat step 3 to program the additional FloR/A remote control. Step 3 may be repeated as many times as necessary to program all available FloR/A remote controls.
5. Verify that the FloR/A remote control(s) can control the gate by pressing one or more buttons individually on the remote control(s).

Wirelessly add new remote control to the SMXI/A Plug-In Receiver

A FloR/A remote control that has been programmed to control a SMXI/A receiver may be used to create other FloR/A remote controls for the same receiver. This procedure needs to be performed within 10 to 20m (30 to 60 feet) of the SMXI/A receiver, but the SMXI/A receiver does not need to be physically accessed.

1. Press and hold any button on the un-programmed FloR/A remote control for at least 5 seconds, then release the button, taking note of the button that was pressed.
2. Press the same button on the programmed FloR/A remote control three times.
3. Press the same button in step 1 on the un-programmed FloR/A remote control and release.
4. It is recommended to test the new copy of the FloR/A remote control with the assigned gate controller.

NOTE: This procedure will affect all SMXI/A receivers within radio range.

Deleting a Single FloR/A Remote Control from the SMXI/A Plug-In Receiver Memory

A FloR/A remote control that has been programmed to control a SMXI/A receiver may be removed from the SMXI/A receiver memory without affecting other assigned remote controls. This procedure needs to be performed at the SMXI/A Plug-In Receiver with the affected FloR/A remote control.

1. Press and hold the button on the side of the SMXI/A receiver until the led on the SMXI/A receiver illuminates green and keep the button pressed. The led will illuminate after approximately 4 seconds.
2. Press and hold any button on the FloR/A remote control until the led on the SMXI/A receiver blinks 5 green flashes.
3. Release the button on the side of the SMXI/A receiver.
4. It is recommended to verify that the de-programmed FloR/A remote control no longer controls the gate.

Deleting all FloR/A Remote Controls from the SMXI/A Plug-In Receiver Memory.

All programmed remote controls may be removed from the SMXI/A plug in receiver memory. This procedures need to be performed at the gate controller.

1. Press and hold the button on the side of the SMXI/A receiver until the led on the SMXI/A receiver illuminates green and keep the button pressed.
2. Watch the led and on the receiver and verify the following sequence in the led.
3. Within 4 seconds after pressing the button (approx.) the green led illuminates.
4. Within 8 seconds after pressing the button (approx.) the green led turns off.
5. With 12 second after pressing the button (approx.) the green led starts flashing.
6. Count the green led flashes on the SMXI/A receiver. On EXACTLY the 5TH flash, release the button on the SMXI/A receiver.
7. It is recommended to test the FloR/A remote controls, if available, with SMXI/A plug in receiver to verify that it no longer affects the gate controller.

4.2.3 - OVIEW REMOTE CONTROL

OVIEW (see page 6 for Picture of OVIEW)

Programming and diagnostic unit which connects directly to the gate controller and is part of the Nice “Opera” control system. The unit can be used in “stand-alone” mode via its front-panel keypad, or it may be accessed via a Bluetooth or cellular-enabled PDA, PC, or Smartphone when used with the O-View Software Suite. This unit, when matched with the OVIEW Bluetooth or GSM modules, enables remote control and management of the gate controller. Remote control functions include most of the programming functions that are available at the front panel LCD on the control board as well as software updates.

OVBT: Bluetooth module for OVIEW and the “O-View Software Suite” application for PC, PDA, or Smartphone for localized wireless control of the gate controller.

OVBTGSM: Combination GSM and Bluetooth module that plugs into the OVIEW and provides cellular phone access through the “O-View Software Suite” application for PC, PDA, or Smartphone, for wireless local, national, and international controller of the gate controller.

O-VIEW Software Suite: Provides desktop or Smartphone level control of the gate controller. Other benefits include software updates that can be made wirelessly as new versions of software are made available.

5 - WIRING AND CONNECTIONS

Use only U.L. listed (or equivalent) non-contact sensors. Inputs from the photo beam to the circuit board are Normally Open (N.O.). Use only U.L. listed (or equivalent) non-contact sensors. Connect the non-contact sensors. Photo-beam input shall REVERSE travel of gate when activated during the CLOSE CYCLE ONLY. Gate will resume normal operation when photo-beam is no longer activated.

To reduce the risk of SEVERE INJURY or DEATH:

- Disconnect power to the gate operator by manually opening its dedicated circuit breaker before making any mechanical or electrical adjustments.
- All wiring connections MUST be made by a qualified individual.
- Run individual circuits in separate U.L. listed conduits. Do not combine high voltage (120VAC) power wiring and low voltage (+12VDC to +24VDC) control wiring in the same conduits.

6 - OPTIONAL INPUTS/OUTPUTS

6.1 - Fire dept. connection

32 FIRE
33 GND

Dry contact input for a fire department control switch. Normally Open (NO) contact must be shorted to ground through a switch to open the gate.

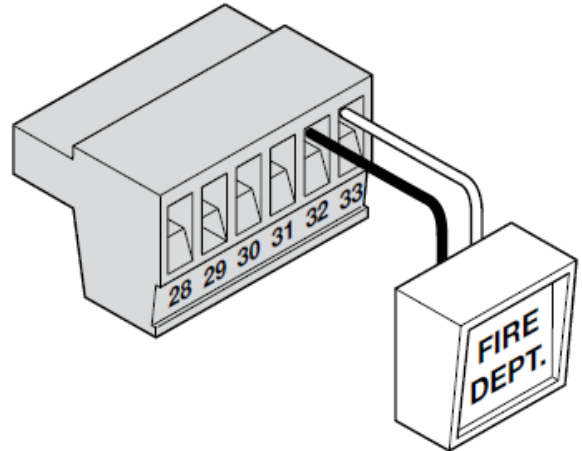

Figure 27 - FIRE DEPT. INPUT

6.2 - Exit and edge inputs wiring diagram

28 EDGE
29 GND
30 EXIT
31 GND

The **EDGE** input may be configured as a monitored ANALOG input, or DIGITAL (NC or NO) input. The EDGE sensor input is intended for ANSI/UL 325 listed gate edge sensors to protect against entrapment and hazardous pinch points along the moving edge of the closing gate.

The **EXIT (NO)** sensor input is provided to activate to open the gate, or re-open a closing gate, upon sensing an exiting vehicle.

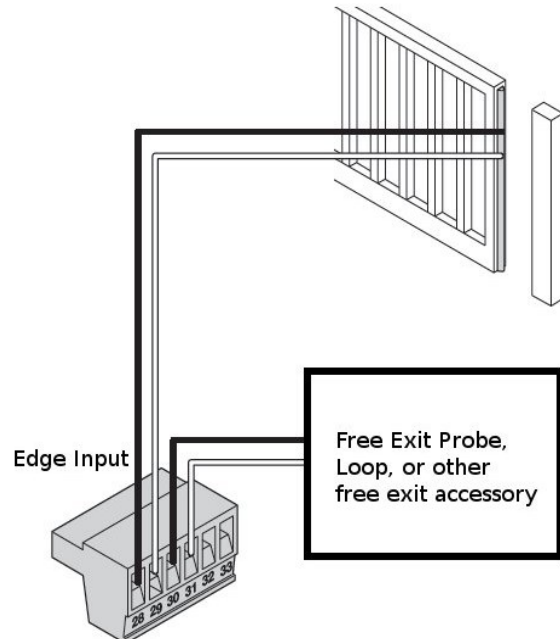

Figure 28 - EXIT AND EDGE INPUTS

6.3 - Guard station

34 OPEN (NO)
35 STOP (NC)
36 CLOSE (NO)
37 GND

With the Guard Station switches installed, the user can operate the gate by pushing the respective buttons for the command that is desired. Gate Open (NO), Stop (NC) and Close (NO), dry contact inputs, are controlled by NORMALLY OPEN (NO) and NORMALLY CLOSED (NC) momentary switches.

NOTE: If the guard station inputs are not used STOP (35) and GND (37) need to be tied together

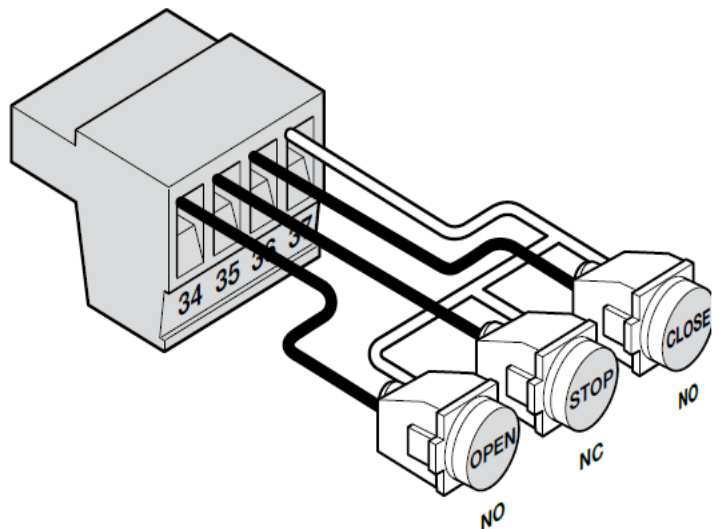

Figure 29 - GUARD STATION INPUTS

6.4 - Magnetic lock connection

- 7 NC
- 8 Com (Common)
- 9 NO
- 10 GND
- 11 V+

This connection is used to install the magnetic lock. In this instance a gate can be locked magnetically to prevent a forced opening. Consult lock manual for specifics on installation and wiring.

Note: Terminal 11 voltage is equal to system input voltage.

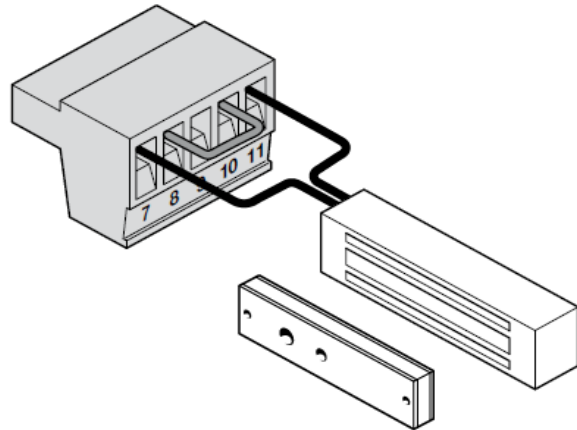

Figure 30 - MAGNETIC LOCK WIRING (EXAMPLE)

6.5 - Radio receiver connection (third party)

- 38 12V
- 39 OPEN
- 40 CLOSE
- 41 GND

The customer supplied radio receiver allows the gate operator to be operated via remote, such as wireless key-card readers or user remote controls. Connecting the Open (39) and Close (40) pins together with a receiver enables single-button gate control. This configuration allows a single button to control the gate in the following sequence:

Press - Gate Open

Press - Gate Stop

Press - Gate Close

Press - Gate Stop

Terminal #38 (12V) is off when the board goes into standby.

Disable standby when using a third party receiver.

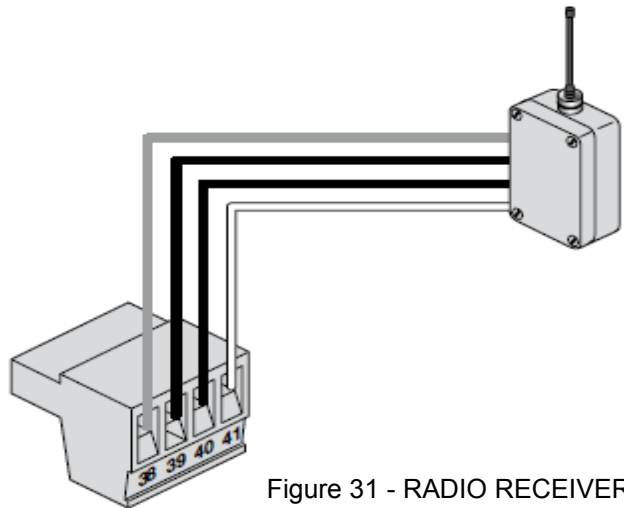

Figure 31 - RADIO RECEIVER

7 - INSPECTION AND OPERATION

Proper inspection of all equipment is required to ensure continuous functionality, safety and to ensure reliable operation in all weather conditions. Inspect electrical assemblies and wiring installations for damage, general condition, and proper functioning to ensure the continued satisfactory operation of the electrical system. Adjust, repair, overhaul, and test electrical equipment and systems in accordance with the recommendations and procedures in the gate operator system and/or component manufacturer's maintenance instructions.

Replace components of the electrical system that are damaged or defective with identical parts, with manufacturer's approved equipment, or its equivalent to the original in operating characteristics, mechanical strength, and environmental specifications. A partial list of suggested problems to look for and checks to be performed are listed below:

- Damaged, discolored, or overheated equipment, connections, wiring, bearing caps and installations.
- Excessive heat or discoloration at high current carrying connections. (look for bluing or heat affected metal).
- Misalignment of electrically driven equipment. (Causes strain on pulley assemblies and bearings).
- Poor electrical bonding (broken, disconnected or corroded bonding strap) and grounding, including evidence of corrosion.
- Dirty equipment and connections. Clean equipment and connections.
- Improper, broken, inadequately supported equipment, wiring and conduit, loose connections of terminals, and loose ferrules.
- Poor mechanical or weld joints. Broken welds.
- Condition of fuses. Ensure that they are of the correct type and amperage.
- Insufficient clearance between exposed current carrying parts and ground or poor insulation of exposed terminals. All exposed connections must be covered (prevent arcing between exposed parts, and electrical shock).
- Broken or missing wire, connectors, etc.
- Operational check of electrically operated equipment such as motors, inverters, generators, batteries, lights, protective devices, etc. Ensure proper functionality of all systems during inspections.
- Ensure safety placards and warning signs are present as specified within this document. Ensure proper functionality of all safety devices as specified. Non-functioning or malfunctioning safety devices should be replaced immediately.

8 - GENERAL LAYOUT AND SAFETY ACCESS

Typical Installation Diagram Utilizing Loop Sensors and Photocells

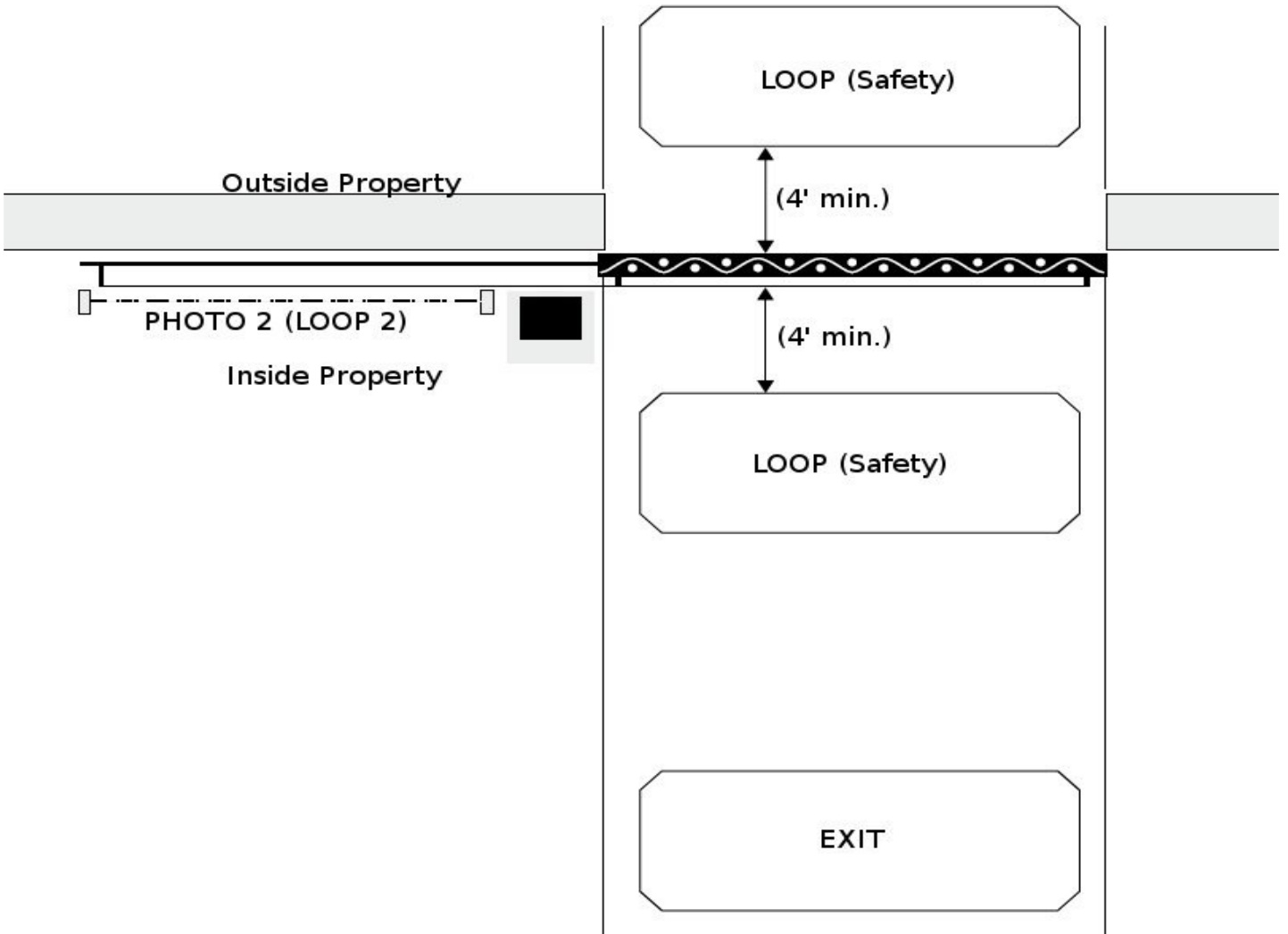

Figure 32 - Loop Sensor and Photocells Installation Diagram

Typical Installation Diagram Utilizing Photocells

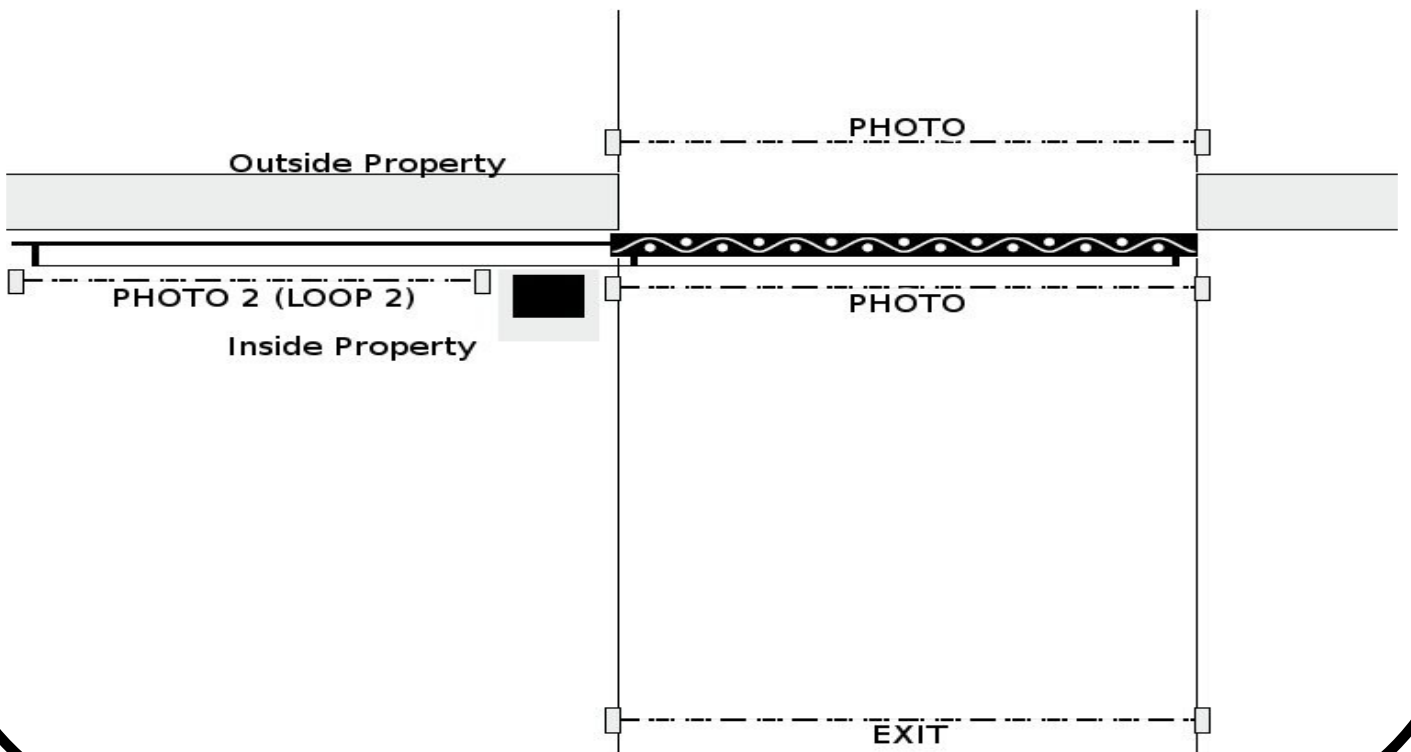

Figure 33 - Photocells Installation Diagram

9 - ACCESSORIES AND SENSORS

EXTERNAL ENTRAPMENT PROTECTION:

Non-contact and contact sensors must be installed individually or in combination with each other to provide external entrapment protection.

Care should be exercised to reduce the risk of nuisance tripping, such as when a vehicle trips the sensor while the gate is still moving, and one or more non-contact sensors shall be located where the risk of entrapment or obstruction exists, such as the perimeter reachable by a moving gate or barrier.

A hardwired contact sensor shall be located and its wiring arranged so that the communication between the sensor and the gate operator is not subjected to mechanical damage.

A wireless contact sensor such as one that transmits radio frequency (RF) signals to the gate operator for entrapment protection functions shall be located where the transmission of the signals are not obstructed or impeded by building structures, natural landscaping or similar obstruction.

DURING INSTALLATION

- DISCONNECT POWER at the control panel before making any electric service power connection.
- Be aware of all moving parts and avoid close proximity to any pinch points.
- Know how to operate the manual release.
- Adjust the unit to use the minimum force required to operate the gate smoothly even during mid-travel reversing.
- Place controls a minimum of 8 feet away from the gate so that the user can see the gate and operate controls but cannot touch the gate or gate operator while operating the controls.
- Warning signs must be placed on each side of the gate or in high-visibility areas to alert of automatic gate operations.

10 - BOARD DIAGRAM

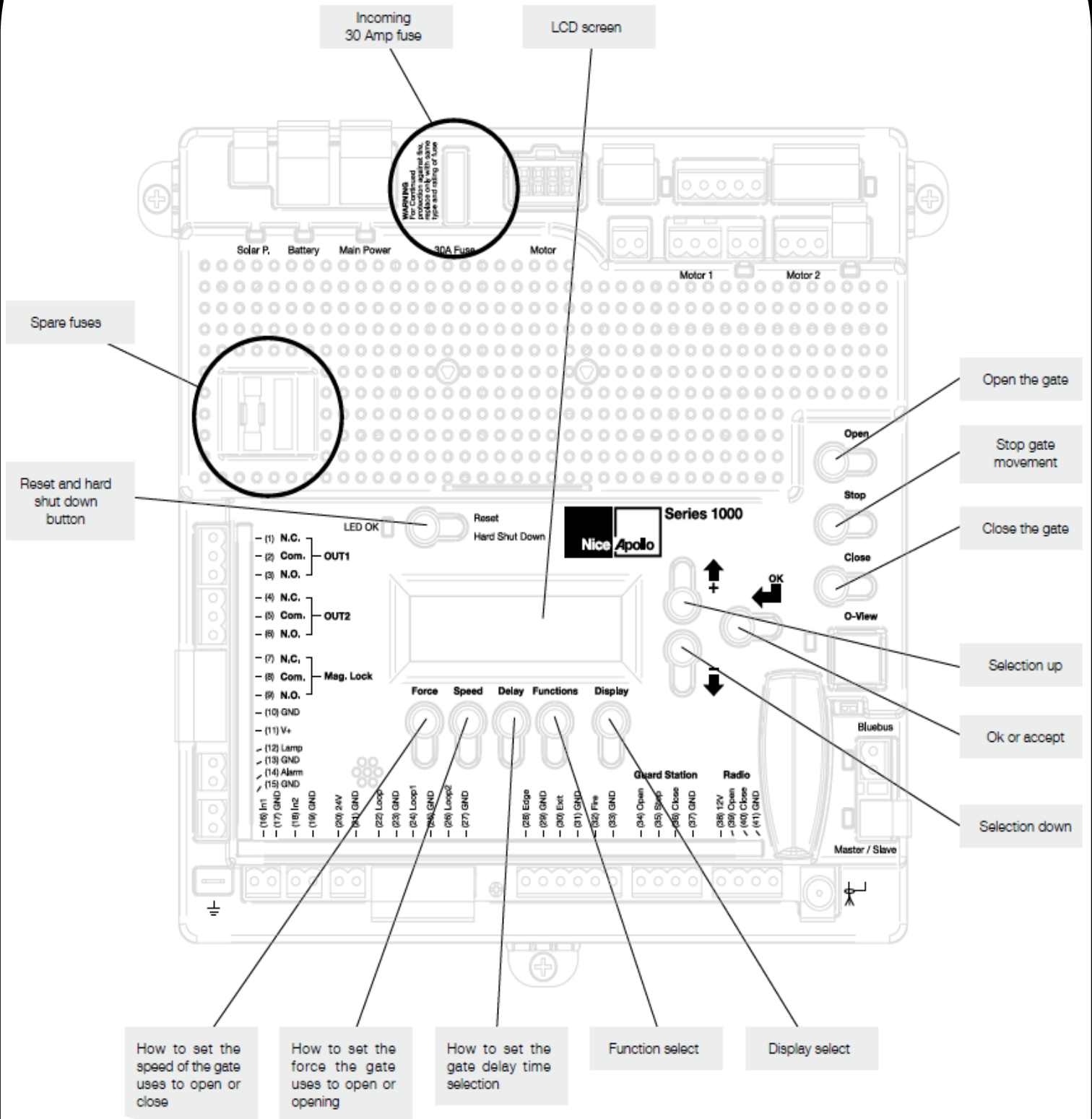

Figure 34 - GENERAL BOARD OVERVIEW

THE PROGRAMMING BUTTONS INDICATED IN THE ABOVE REFERENCE SHOULD BE USED ONLY AFTER UNDERSTANDING THE MANUAL AND ITS RELATION TO THE PROGRAMMING SEQUENCES SHOWN ON THE FOLLOWING PAGES. CARE SHOULD BE TAKEN WHENEVER CHANGES ARE IMPLEMENTED TO ENSURE PROPER FUNCTIONALITY AND SAFETY.

11 - PROGRAMMING BUTTONS

11.1 - Force

Static: Set sensitivity to constant force on a scale of 1 to 10 (1 being the most sensitive).

Dynamic: Set sensitivity of sudden impact force to the moving gate on a scale of 1 to 10 (1 being most sensitive).

ESC: Exit the FORCE menu.

11.2 - Speed

Max: Sets the limit of maximum allowed gate speed on a scale of 20% to 100% (20% being the lowest setting).

Standard: Sets the limit of the gate speed during normal movement (not soft start/stop) on a scale of 20% to MAX (20% being the lowest setting).

Low: Sets the limit of the gate speed while in LEARNING mode and when moving in SLOW, on a scale of 20% to 100% (20% being the lowest setting).

Slowdown: Set gate speed when going into approaching the open or close limits on a scale of 20% to 100% (20% being the lowest setting).

11.3 - Acceleration

Max: Sets the limit of gate acceleration when reversing the gate after an obstacle has been detected by the UL/Edge or current sense feature (Force). Settings from 3 to 10, with 10 being the highest rate of gate acceleration.*

Standard: Sets the limit of the gate acceleration in normal operation. Settings from 1 to MAX, with MAX being the highest rate of gate acceleration.

****TO PREVENT DAMAGE TO THE GATE OR THE CONTROLLER USE LOWER ACCELERATION SETTINGS FOR HEAVIER GATES.**

ESC: Exit the SPEED menu.

11.4 - Delay

Auto Close: Sets the timeout before the gate closes automatically from the fully open position. Settings from 0 (off) to 90 seconds. Setting this to 0 will disable the auto close timer.

Slave: Sets the delay for opening the slave gate leaf in a Master/Slave (Motor 1 and Motor 2 operation), (dual gate) system. Settings from 0 to 5 seconds with a step of 0.5 seconds.

Lamp/Strobe: Sets the amount of time the Lamp accessory output is activated prior to gate movement. Settings from 0 to 5 seconds with a step of 0.5 seconds.

Lock: Sets the amount of time the Magnetic Lock accessory output is activated to disable the lock when opening the gate. Settings from 0 to 5 seconds with a step of 0.5 seconds.

Run Time: Sets the maximum run time for the gate. Used in case the gate doesn't reach its limits. Settings from 15 to 120 seconds with a step of 1 second.

ESC: Exit the DELAY menu.

11.5 - Function

Learn: Puts the gate operator into learning mode for a Slide or Slide gate and Blue BUS peripherals. Learning mode for a Slide or Slide style gate involves selecting the gate type (Light, Average, Heavy), then fully opening and closing the gate to sense the limits. Selecting the gate type selects precalculated values for the FORCE, SPEED, and ACCELERATION settings. Learning the Blue BUS peripherals enables the gate operator to discover and integrate accessory devices like Blue BUS access control and safety devices.

Positions: Configures the points in the gate open, close, and partial cycles at which deceleration occurs.

- **Slow Down – Open:** Sets the point in the % of gate opening when the gate begins deceleration to the fully open position.
- **Slow Down – Close:** Sets the % of gate opening when the gate begins deceleration to the fully close position.
- **Partial:** Sets the point in the % of gate opening when the gate begins deceleration to the Partial open position.

Auxiliary Inputs: Auxiliary inputs IN AUX1 (16) and IN AUX2 (18) can be programmed with one of the following options:

- No program No Function used
- OPEN the Gate
- CLOSE the Gate
- STEP Cycling Step (Open-Stop-Close-Stop)
- PARTIAL opening
- PARTIAL 1 Partial Opening 1 (open one leaf in dual gate applications)
- STOP the gate and Auto-closing
- HOLD TO OPEN Input must be maintain active for Opening
- HOLD TO CLOSE Input must be maintain active for Closing
- FIRE Reset Hard Shut Down and Open the Gate
- TIMER 1 Start Count Down TIMER1
- TIMER 2 Start Count Down TIMER2
- PHOTO Photocell PHOTO input: reverse to opening when closing
- PHOTO1 Photocell PHOTO1 input: Stop Gate when activated
- PHOTO2 Photocell PHOTO2 input: reverse to closing when opening
- SHADOW Loop input: prevent closing gate when completely open
- LOCK system from other command (only STEP H overrides the Block)
- UNLOCK Un-lock the system if locked
- OPEN and LOCK Open the Gate and inhibit further commands (except STEP H)
- CLOSE and LOCK Close the Gate and inhibit further commands (except STEP H)
- OPEN and UNLOCK Open the Gate and un-inhibit further commands
- CLOSE and UNLOCK Close the Gate and un-inhibit further commands
- STEP H Command high priority Step cycling (open-stop-close-stop)

Auxiliary Outputs: Auxiliary outputs OUT AUX1 (1,2,3,) and OUT AUX2 (4,5,6,) can be programmed with one of the following options:

- NO PROGRAM Output not used
- OPEN Output is activated when Gate is open
- CLOSE Output is activated when Gate is closed
- MOVING Output is activated when Gate is moving
- TIMER 1 Output is activated when TIMER1 is counting down
- TIMER 2 Output is activated when TIMER2 is counting down
- LOCK Output is activated when the Gate is locked
- MAINT Output is activated when the maintenance cycle counter decrements to 0

11.5 - Function (continued)

Radio Channel: For the Plug-in Onboard Receiver, 15 radio channels may be programmed with one of the following options:

- No program
- OPEN (Default CH. 2)
- CLOSE
- STEP (Default CH. 1)
- PARTIAL
- PARTIAL 1
- STOP
- HOLD TO OPEN
- HOLD TO CLOSE
- TIMER 1
- TIMER 2
- LOCK
- UNLOCK
- OPEN and LOCK
- CLOSE and LOCK
- OPEN and UNLOCK
- CLOSE and UNLOCK
- STEP H
- TOGGLE and LATCH

Timers:

Set time for count down timers Timer 1 and Timer 2. Settings between 1 second and 9 hours in 1 second increments.

Events:

Up to 8 weekly events (EV1 through EV8) can be programmed and stored. Each event can be programmed to trigger at a specific time and can be assigned to any combination of days of the week (Monday through Sunday). Events that are already programmed into the system may be suspended temporarily, or removed permanently from memory. The following actions can be assigned to events:

- No program
- Open
- Close
- Partial
- Partial1
- AxOut1 On
- AxOut1 Off
- AxOut2 On
- AxOut2 Off
- Open and Lock
- Close and Lock
- Open and Unlock

11.5 - Function (Continued)

Events (continued)

To program weekly events EV1 through EV8, perform the following steps:

1. Press FUNCTION -> Events.
2. Press and hold OK to display EV1 (display will blink "EV1").
3. Press UP or DOWN to toggle between events, then press OK to make a selection. The display changes to hours.
4. Press UP or DOWN to toggle between hours, then press OK to make a selection. The display changes to minutes.
5. Press UP or DOWN to toggle between minutes, then press OK to make a selection. The display changes to individual days of the week.
6. Press UP or DOWN to toggle between days of the week. Press OK to toggle between ON and OFF for each day of the week. Continue toggling through the days of the week until ESC is displayed. Press OK to advance to the next event.
7. Repeat step 2 through 6 for event EV2 through EV8.

To temporarily suspend one or more weekly events (EV1 through EV8), perform the following steps:

1. Press FUNCTION -> Events.
2. Press OK quickly to display EV1 active days.
3. Press OK quickly again to display "Suspend". Event EV1 is now suspended and will not run until re-enabled.
4. Press UP or DOWN to toggle through the events EV1 – EV8 and repeat steps 2 through 3 to suspend or enable other weekly events.

Charger:

A battery charger is built-in with the Control board for use with a backup battery. The charger may be manually programmed for customized charge settings or set to "Auto" to provide a battery charging profile that automatically compensates for temperature and current during the charging process. The following parameters are available for programming the battery charger:

- Charger On/Off
- Select Max current for charging (from 0.1A to 1.5A step 0.05A)
- Cycling Time (1 second off charging every cycling time)
- Auto (best charge considering temperature)

Standby:

Programs the timeout for the gate operator to go into low power standby mode. Low power standby is Settings from 5 to 120 seconds, or may be disabled with "OFF". During low power standby there is no data displayed on the gate operator LCD and it consumes a minimum amount of power to extend the life of the backup battery. All the outputs are switched off and the LED OK blinks to show this standby status of the system.

Note: Terminals 11, 20, and 41 lose power in standby mode.

11.5 - Function (Continued)

Advance Settings:

The following settings are available for customizing the gate operator as required by the customer's installation requirements:

- Set Language (English, Spanish, Italian)
- Set clock 12H/24H
- Set LCD Contrast
- Direction of the Motor (only selectable in learning mode)
- Auto Close Opt. (ON - Gate only closes when at open limit, OFF - Gate auto-closes from any open position)
- Exit Opt. (ON - Free Exit always opens gate, OFF - Free Exit doesn't open gate if stopped while opening)
- Set Anti-tailgate (Closes gate immediately after vehicle has cleared safety sensors)
- Phototest (activates monitoring feature for BlueBus photoeyes)
- Select inputs LOOP or PHOTO
- Select UL/EDGE input type (NO, NC, Analog)
- Select Master / Slave Motor1 or Motor2
- Activate link for remote Master/Slave (Enables control of an additional gate operator board - Not Applicable in this installation)
- Power Fail Open (Opens gate automatically on batter backup power if main AC power input loss is detected) (Not Applicable in this installation)
- Motor 12V (Forces motor control voltage to +12VDC even if the supply voltage varies from +9.5VDC up to +35VDC)
- Set Virtual Encoder (Used for motors without built-in encoders)

Default: This setting gives the installer/user the option of returning some or all settings of the gate operator to the original factory settings:

- System settings
- Radio Channel settings
- Event settings
- Charger settings

ESC: Exit the FUNCTION menu.

11.6 - Display

ESC: Exit the DISPLAY menu.

Info: Displays the manufacturer name, product name/model, software versions, and serial number.

Clock: Displays the calendar date and time in the real time clock. Pressing and holding the "OK" button for 5 seconds enables the date and time settings to be updated manually.

Main Volt: Displays the gate operator main control voltage in volts DC.

Battery Volt: Displays the gate operator backup battery voltage in volts DC.

Sun Volt: Displays the solar panel input voltage in volts DC.

Motor Volt: Displays the voltage at the motor in volts DC.

UL Volt: Displays the voltage at the UL/Edge sensor input in volts DC.

Temperature: Displays the temperature of the gate controller board in degrees Centigrade or Fahrenheit (press OK and hold 5 seconds to change scale).

Service: The following information is recorded and viewable about the operating history of the gate:

- Total: Displays the total number of open-close cycles (non- Settings).
- Partial: Display the total number of partial cycles. Reset by pressing the "OK" button for several seconds.
- Maint. Display the number of cycles before service is required. Settings from 1000 to 50000 cycles in increments of 1000 cycles.

Motor: Displays the Motor position, voltage, and current.

Motor 1: Displays the Motor1 position, voltage, and current.

Motor 2: Displays the Motor2 position, voltage, and current.

Charger: Displays the battery charger voltage and current.

Last Reset: Displays the code for diagnostic review. Used for diagnostic and troubleshooting.

12 - GLOSSARY

CLASS I - RESIDENTIAL VEHICULAR GATE OPERATOR- A vehicular gate operator (or system) intended for use in a home of one-to four single family dwelling, or garage or parking area associated therewith.

CLASS II - COMMERCIAL / GENERAL ACCESS VEHICULAR GATE OPERATOR - A vehicular gate operator (or system) intended for use in a commercial location or building such as a multi-family housing unit (five or more single family units), hotels, garages, retail store, or other building servicing the general public.

CLASS III - INDUSTRIAL / LIMITED ACCESS VEHICULAR GATE OPERATOR - A vehicular gate operator (or system) intended for use in an industrial location or building such as a factory or loading dock area or other locations not intended to service the general public.

12 - GLOSSARY (Continued)

CLASS IV - RESTRICTED ACCESS VEHICULAR GATE OPERATOR - A vehicular gate operator (or system) intended for use in a guarded industrial location or building such as an airport security area or other restricted access locations not servicing the general public, in which unauthorized access is prevented via supervision by security personnel.

LOCK- Ceases all operator function except HIGH PRIORITY inputs.

ENTRAPMENT - The condition when an object is caught or held in a position that increases the risk of injury.

FORCE STATIC - Constant load threshold for sensitivity setting.

FORCE DYNAMIC - Impact sensitivity setting.

GATE - A moving barrier such as a swinging, sliding, raising, lowering, or the like, barrier, that is a stand-alone passage barrier or is that portion of a wall or fence system that controls entrance and/or egress by persons or vehicles and completes the perimeter of a defined area.

(STEP H) HIGH PRIORITY - Step by step control.

INHERENT ENTRAPMENT SENSOR SYSTEM - An automatic sensor system which senses entrapment of a solid object and is incorporated as a permanent and integral part of the operator.

STEP BY STEP - Command that opens-stops-closes-stops the gate with each press of the button.

SYSTEM - In the context of these requirements, a system refers to a group of interacting devices intended to perform a common function.

UNLOCK - Resumes normal operation after a blocked condition.

WIRED CONTROL - A control implemented in a form of fixed physical interconnections between the control, the associated devices, and an operator to perform predetermined functions in response to input signals.

WIRELESS CONTROL - A control implemented in means other than fixed physical interconnections (such as radio waves or infrared beams) between the control, the associated devices, and an operator to perform predetermined functions in response to input signals.

TOGGLE AND LATCH - When radio channel set to TOGGLE and LATCH, first activation will open and hold gate open (LATCHed). Second activation will unlatch gate and allow it to autoclose or be closed by some other method.

13 - EMERGENCY VEHICLE ACCESS

- The automatic vehicular gate system must be designed to allow access to emergency vehicles under different operating conditions.
- During normal powered operation, emergency vehicles access the gate by use of the emergency vehicle access device installed on your gate system. The type of device that is used in your community is dependent on your city codes. These devices may include (but are not limited to) Fire Department lock boxes, Click-2-Enter radio receivers, strobe light sensors, siren sensors, etc.
- If applicable, this operator is equipped with a manual release system that will allow the gate to be pushed open in the event of a power outage or equipment failure.
- NOTE: Never attempt to manually push open any gate with an operator attached to it until you have verified that power to the operator has been shut-off.
- The automatic vehicular gate system must be designed to allow access to emergency vehicles under different operating conditions.
- In the event of a power failure, the emergency vehicle access device may not be functional because the gate operator is un-powered. NOTE: DC powered back-up systems are optional and your gate system may or may not be equipped with one. Check with your installer to determine if your gate system is equipped with a back-up power system.

14 - MAINTENANCE SCHEDULE - APOLLO GATE OPENER

TABLE 2

		COMPLETE	BASIC
Alarm	Active the primary (inherent) reverse system by blocking the gate with a solid object. The gate should reverse momentarily then stop. Restart the gate and Lock again with a solid object. The gate should reverse momentarily, then stop, and go into hard shutdown with an alarm	•	•
Battery	Check the batteries for any leakage or loose connections. Batteries should be replaced every two years	•	
Fire Dept	Check emergency vehicle access device for proper operation	•	•
Gate	Inspect for damage	•	
Reverse System	Check that the gate reverses on contact with an object in both the opening and closing cycles	•	•
Loop(s)	Check vehicular reverse and shadow loops for proper operation	•	•
Release	Check manual release for proper operation	•	
Complete	Overall Check: Complete check of gate and gate operating system	•	
Mounting Hard-	Check screws and nuts	•	

15 - APOLLO GATE OPENER TROUBLESHOOTING

TABLE 3

SYMPTOM(S)	POSSIBLE SOLUTION
Operator will not power On. Power LED is OFF	<ul style="list-style-type: none"> • Check terminal Lock wiring for loose or broken wires • Check the fuse
Gate opens a short distance, then stops and reverses	<ul style="list-style-type: none"> • Check the UL/Edge input on the gate controller • Adjust Force Settings • Check Motor 1 and Motor 2 encoder LEDs to verify the LEDs toggle
Gate opens but will not close	<ul style="list-style-type: none"> • Check the input LEDs. Any ON will hold the gate open and indicates a problem with a keying device • Check the secondary safety devices. Any activated safety devices will hold the gate open and indicates a problem with the safety device • Check the loop detectors. Any activated safety devices can hold the gate open and indicates a problem with the loop detector or ground
Hard Shutdown (2 back to back obstructions) LED blinking, Buzzer sounds for 5	<ul style="list-style-type: none"> • Clear any obstructions from the path of the gate. Press RESET to clear (or hard reset button)
Gate opens by itself	<ul style="list-style-type: none"> • Check accessory inputs and clear them as necessary

16 - APOLLO 7300ETL-1K PROGRAMMING QUICK START

Learning 7300ETL-1K Actuator

1. Install electrical power to the gate opener unit.
2. Install all gate accessories such as Photo-Eye's, Sensors, Loops and other safety devices.
3. Turn on the electrical power to the unit.
4. Using the MANUAL RELEASE HANDLE, disengage the drive motor. See Figure 18 - 7300ETL-1K MANUAL RELEASE.
5. Move the gate manually (with your hands) to ensure that the gate travels to the fully open and fully closed positions with no binding or problems. Gate should move freely.
6. Using the MANUAL RELEASE HANDLE, re-engage the drive system.
7. See Figure 17 - 7300ETL-1K MANUAL ENGAGE.
8. Using the open button on the front of the Control board, hold the button down until the gate reaches the fully open position. If the gate moves in the opposite direction swap the RED and BLACK motor leads at the 3-pin motor power connector on the control board.
9. Adjust the Open Limit Switch until the GREEN light illuminates on the front of the control board. The FULLY OPEN limit switch is now set.
10. Using the CLOSE button on the front of the Control Board, hold the button down until the gate reaches the fully closed position.
11. Adjust the CLOSED Limit Switch until the RED light illuminates on the front of the control board. The fully CLOSED limit switch is now set.
12. The control board is already in the "LEARNING MODE" when shipped. If not in LEARNING MODE, press FUNCTION, then press LEARN, then press SLIDE, then select LIGHT, AVERAGE < or HEAVY, then press ENTER to start the gate learning process.
13. The gate will open partially then stop. This is being done, so that the control board can sense the type and operational condition of the drive motor. The gate will then run to the closing limit, so that it can properly sense where it is located.
14. The control board will then OPEN the gate slowly to establish travel and limits.
15. Once the gate reaches the fully OPENED limit switch, the control board will now increase gate travel speed to the highest speed allotted, and will now travel to the fully CLOSED position at full speed.
16. The gate opener is now programmed for basic usage.

17 - Putting the controller into learning mode

Steps on how to place the Apollo 1050 control board into learning mode.

1. Press Function
2. Press OK
3. Select Slide
4. Select weight of gate (LIGHT , AVERAGE, or HEAVY)
5. Press Enter

Unit should now be in **LEARNING MODE**

18 - INSTALLATION CHECKLIST

Left box is for installer check off and the right box is for customer check off.

- 1. The gate has been checked to make sure it is level and moves freely in both directions.
- 2. Potential pinch areas have been guarded so as to be inaccessible OR have contact and/or non-contact obstruction sensing devices installed.
- 3. The installer has installed one or more contact or non-contact obstruction sensing devices, in compliance with UL325 requirements for this installation.
- 4. If pedestrian traffic is expected, a separate pedestrian gate has been installed, a minimum of seven feet from the gate. The customer has been informed that all pedestrian traffic must use the pedestrian gate.
- 5. Warning signs have been installed on each side of the gate in highly visible locations. The customer has been informed that these signs must remain at all times.
- 6. There are no controls installed on the gate operator, or within 8 feet of the gate.
- 7. The installer has properly adjusted the obstruction sensing feature and has tested the gate to make sure that the gate stops and reverses a short distance with minimal resistance applied (Approximately 75 lbs. on a slide gate, at the end of the gate).
- 8. The installer has instructed the customer in the proper use of the gate operator and reviewed all of the operational functions, obstruction sensing devices, warning beeper and reset, etc.
- 9. The installer has instructed the customer in the proper use of the operator's manual disconnect feature. The manual disconnect must never be used while the gate is in motion. The power switch must be turned off before using the manual disconnect and disengaging the operator.
- 10. The installer has reviewed all safety instructions with the customer, and has left the safety instructions and owner's information sheets for their reference.
- 11. The installer has answered any questions the customer has regarding the operation of the gate operator and gate operator safety precautions.
- 12. The installer has explained to the customer that a regular maintenance schedule for both the gate and the gate operator is recommended.

Installation Acceptance _____

Address where opener is located _____

Installer name, number and address _____

End user name and telephone number _____

LIMITED TWO-YEAR WARRANTY

Apollo Gate Operators are warranted against defects for a period of 24 months from the date of purchase, providing recommended installation procedures are followed. This warranty is in lieu of all other warranties expressed or implied (some states do not allow limitations on how long an implied warranty lasts, so this limitation may not apply to you) and shall be considered void if damage was due to improper installation or use, connection to improper power source, or if damage was caused by fire, flood, or lightning. The manufacturer will not be responsible for any labor charges incurred in the removal or replacement of defective parts.

In case of failure due to defective material or workmanship during the warranty period, the defective part will be repaired or replaced at the manufacturer's option at no charge if returned freight prepaid. New or factory rebuilt replacements may be used. Replacement parts are warranted for the remaining portion of the original warranty period. The manufacturer will pay standard ground freight on the return of repaired or replaced items in warranty.

Nice Group USA Inc.
12625 Wetmore Road Suite 218
San Antonio, TX 78247
Ph. +1.210.545.2900
Fax +1.210.545.2915
www.niceapollo.com

